

Daikin Altherma 3 R MT  
The Quintessence of heat pump  
**Product catalogue**



**Mid temperature air-to-water heat pump,  
optimized for boiler replacement**

Heating, cooling and domestic hot water





# Table of contents

<b>The ideal boiler replacement</b> .....	<b>4</b>
<b>Daikin Altherma 3 R MT</b> .....	<b>6</b>
The Quintessence of heat pump .....	6
Innovation at the heart of our concerns.....	8
One solution, multiple combinations .....	10
Get the best comfort with the best functionalities .....	11
Floor standing unit with integrated tank .....	12
Floor standing unit with integrated ECH <sub>2</sub> O tank.....	20
Wall mounted unit .....	30
<b>Thermal stores and tanks</b> .....	<b>36</b>
Daikin Altherma HPC floor standing .....	40
Daikin Altherma HPC wall mounted .....	42
Daikin Altherma HPC concealed .....	43
<b>Controls</b> .....	<b>46</b>
Onecta App .....	46
Madoka .....	48
<b>Stand By Me</b> .....	<b>50</b>
<b>Combination table and options</b> .....	<b>54</b>



# The ideal boiler replacement gets extended

## Ideal to replace gas boilers

Houses built in the 90s often need a refurbishment to still look up-to-date.

In a renovation project, this is also important to consider changing your initial heating system.

Daikin Altherma 3 R MT come as a perfect replacement in such houses, where a leaving water temperature of 65 °C is sufficient. Easy to install, you can even leave the recent radiators installed!

## Suitable for medium sized new buildings

With a capacity range going from 8 to 12 class, Daikin Altherma 3 R MT also fit in medium sized new buildings.

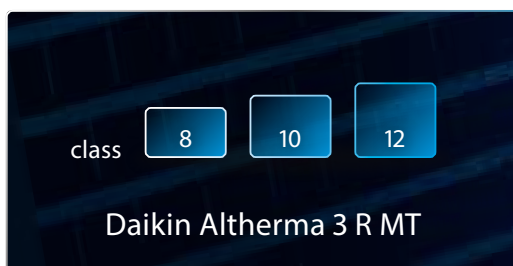



# Daikin Altherma 3 R MT offers multiple possibilities to adapt to your customers needs

- ✓ A leaving water temperature up to 65 °C makes it **a suitable choice for refurbishments**
- ✓ **Best seasonal efficiencies** providing the highest savings on running costs
- ✓ Perfect fit for **new buildings**, as well as for low energy houses



## Refrigerant split version

Daikin Altherma 3 range presents a new addition to the family – refrigerant split version for medium temperature heat pump.

Daikin Altherma 3 R MT relies on a compressor and a refrigerant to transfer the energy from the air to the water. The Refrigerant split unit provides cooling next to heating and domestic hot water.

## Better fit with hydrosplit versions ?

The Daikin Altherma 3 solutions for replacment do come also in hydrosplit versions, 3 H MT and 3 H HT. More information can be found here:



# The Quintessence of heat pump

meeting modern society's expectations



## Made in Europe, for Europe

European weather can be tough sometimes. That's why we designed the Daikin Altherma 3 R MT.

Heating capacities are also maintained high by low ambient temperature thanks to genuine Daikin technology.

As the market leader, Daikin is always striving to make the most reliable and efficient heat pumps possible. Daikin developed the Bluevolution technology to achieve higher and greener performance. This technology is now part of all our heat pumps. Its single fan reduces the noise level and its black front grille makes the unit fit into any environment.

All these dedicated components were developed in-house to make the quintessence of heat pump unique.

**Superior performance, renewable energy use, design and acoustic comfort.**  
**This is what the Quintessence of heat pump is all about.**

## BLUEvolution

The Bluevolution technology combines a specifically developed compressor and the R-32 refrigerant. Daikin is one of the pioneers in the world to launch heat pumps equipped with R-32. With a lower Global Warming Potential (GWP), the R-32 is equivalent in power to standard refrigerants, but achieves higher energy efficiency and lower CO<sub>2</sub> emissions.

Easy to recover and re-use, R-32 is the perfect solution to attain the new European CO<sub>2</sub> emission targets.

**R-32**

## Timeless design and space-saving installation

Aside from the acoustic comfort, design is a decisive point nowadays. Specific attention was paid to making the outdoor unit blend in with your home.

The black front grille stretches horizontally making the fan inside invisible. The mat grey casing reflects the colour of the wall behind for more discretion. When first launched, this unit received two design awards in 2019. This award winning design has been continued in the new models.

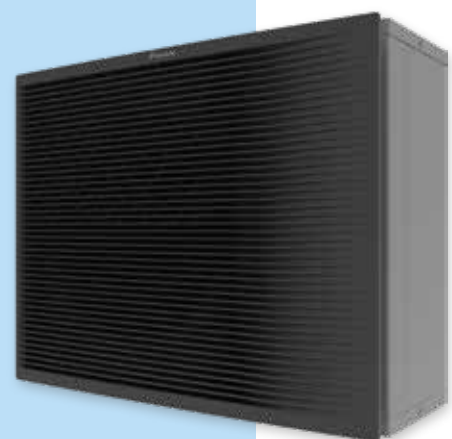



## Silence rhymes with comfort

The Quintessence of heat pump has been designed to reduce its acoustic level and meet the expectations of today's society.

In standard sound mode, the unit produces a sound pressure of 38 dBA at 3 metres, so somewhere between birds chirping and the inside of a library.

The unit also offers greater flexibility by having a low sound mode that reduces the sound pressure at 3 metres to 35 dBA, representing a real reduction of half the sound level!

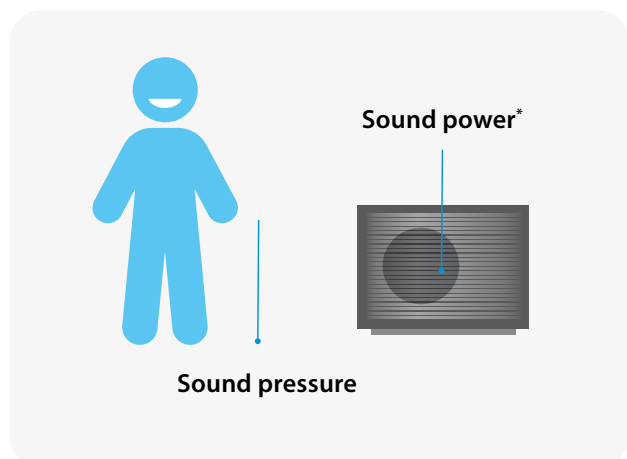
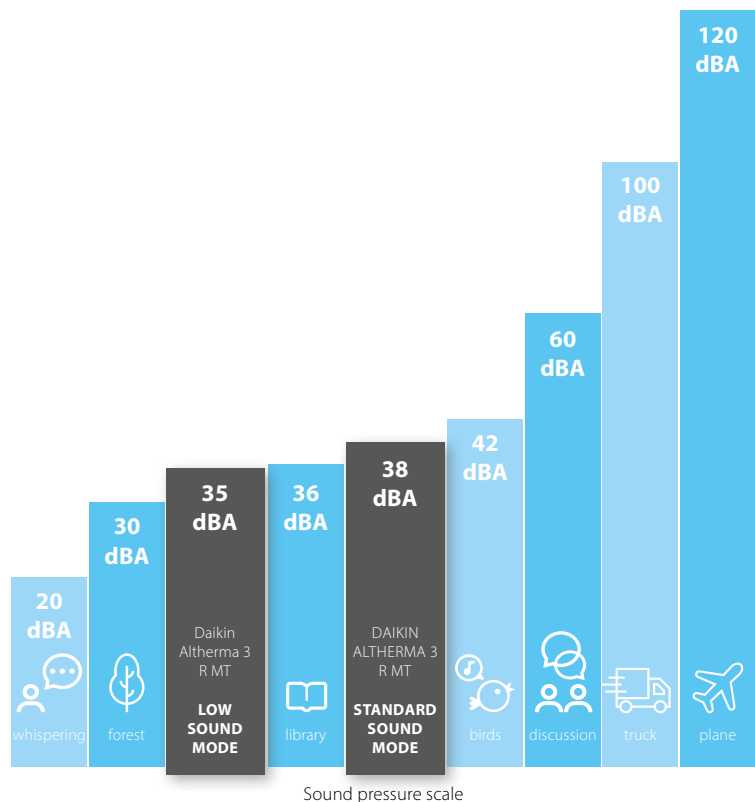

## The acoustic level can be evaluated in two ways

- › The **sound power** is generated by the unit itself, independently of distance and environment
- › The **sound pressure** is the sound perceived at a certain distance. The sound pressure is usually calculated at between 1 and 5 metres from the unit.

\* Erp sound power: Daikin Altherma 3 R MT: 56 dBA



# Innovation At the heart of our concerns

The Daikin Altherma 3 R MT is at top of low sound and heating performances thanks to dedicated developments. Several major components are designed to make this product reach the excellence such as a double injection compressor and a single fan even for large capacity units as well as a brand-new casing.

## A contemporary design casing

The black front grille made of horizontal lines is hiding the fan from view, reducing the perception of the sound produced by the unit.

The light grey casing is slightly reflecting the environment where the unit is installed, helping it to blend in in any decor.

This unique design already got design awards.



reddot design award  
winner 2019

## A single fan for all capacities

The single fan is slightly larger, replacing the usual double fan for high capacity units (classes 8-10-12).

The shape of the fan has also been reviewed to reduce the contact surface with air therefore lower the sound level by improving the air circulation.



## Compressor insulation and anti-vibration

To reduce the compressor sound power, several actions were taken in terms of absorption and insulation.

First, the compressor is surrounded by a 3-layer insulation made of air, insulation material and a metal box.

Regarding the absorption, the unit benefits from a double sound reduction by using rubber pads between the bottom plate and the vibration plate under the compressor.

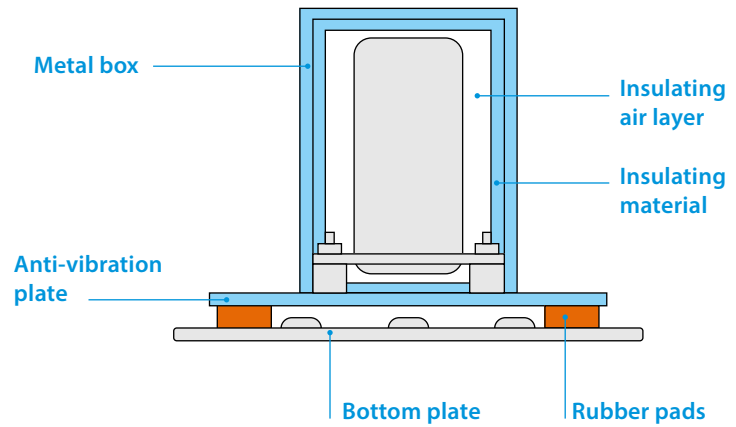

## New double injection compressor

To make this product unique, Daikin Europe cooperated with Daikin Japan to develop top notch components. Daikin Altherma 3 R MT is available in classes 8-10-12 delivers up to 65 °C leaving water temperature.



## Impressive performance

In line with our other heat pump models optimized for replacement, the Daikin Altherma 3 R MT reaches the best performances illustrated in the energy labels:



# One solution, multiple combinations

The Quintessence range can be combined with three different indoor units to connect to the outdoor unit, offering specific features to ensure heating, cooling and domestic hot water in your home.

## Outdoor unit

The outdoor unit is available in 3 classes for 3 R MT: 8-10-12 kW



## Integrated DHW stainless steel tank model

This model is a compact unit with a small footprint of 595x625 mm. The unit is equipped with a tank of 180 or 230 L to answer your domestic hot water demand. Optionally, you can choose the cooling or the bizonne functions.



## Integrated ECH<sub>2</sub>O DHW tank model

The ECH<sub>2</sub>O unit is equipped with a thermal DHW tank of 300 or 500 L that can be connected to thermal solar panels. Optionally, you can choose the cooling function.



## Wall mounted model

This model is the most compact unit but needs to be with a separate tank to deliver domestic hot water. Optionally, you can choose the cooling function.



See exact dimensions per model in the specification tables (p22-29).



# Get the best comfort

## with the best functionalities

Choose from the Daikin "Three Pluses" the functionality that best fits your customer's needs. The indoor units come in 3 possible versions: heating only, reversible and bizona, giving you the opportunity to tailor your Daikin heating system.

### + Heating only model

The heating only model is standard in the Daikin product range and is available for all three indoor units. This means that your heating system provides space heating and domestic hot water.

### + Reversible model

If cooling is needed, all three indoors have dedicated reversible models. Reversible means that the system can invert its way of working and provide cooling instead of heating. The cooling function requires a underfloor piping system or heat pump convectors.

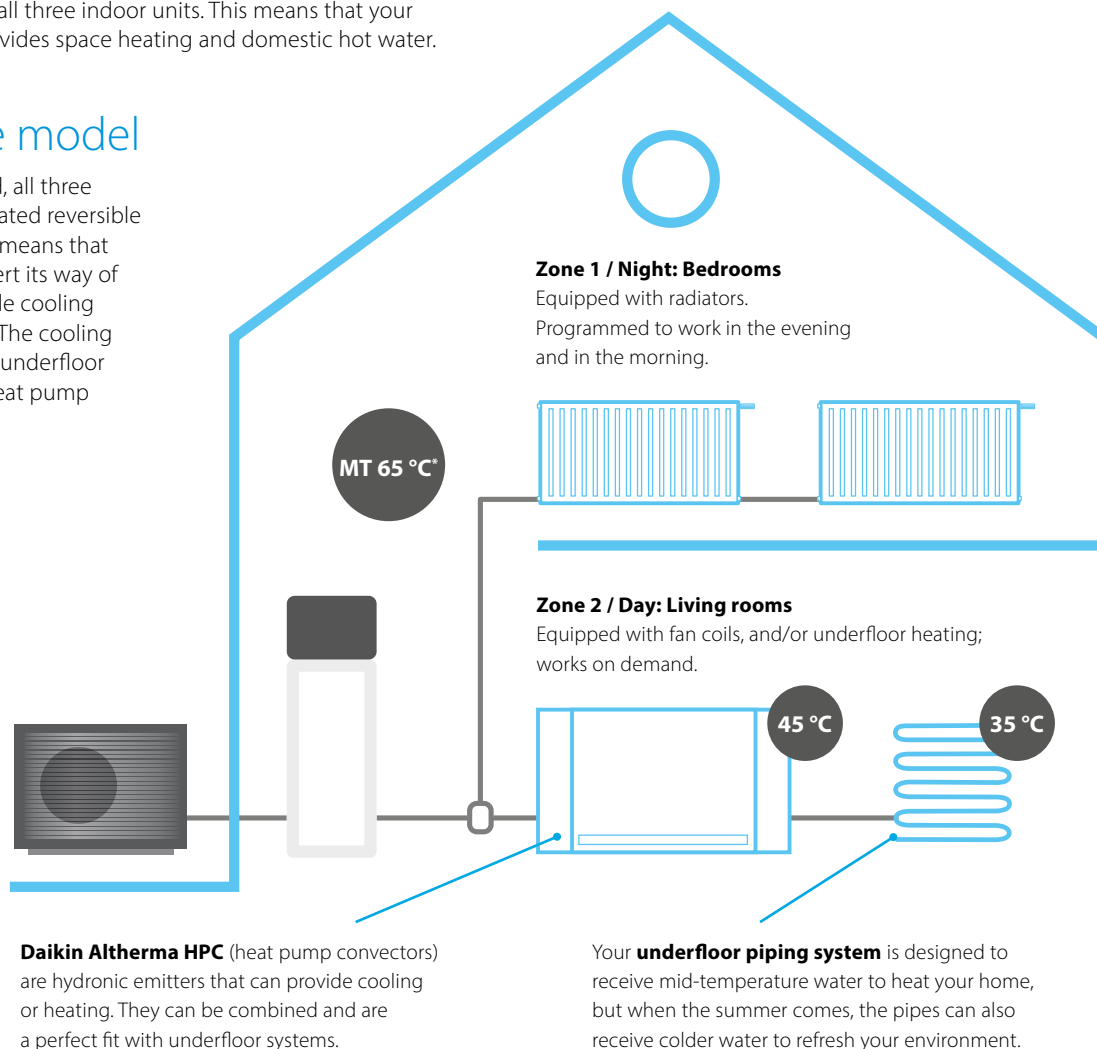

### + Bizona model

Only the DHW stainless steel tank model has a dedicated bizona model: you can choose two independent zones with different emitters that need a different temperature level in different rooms (example: underfloor system in the living room and radiators in the bedroom upstairs).

The 2 zones can also be managed independently: deactivate heating on the first floor during the day in order to reduce over consumption.

\* Daikin Altherma 3 R MT produces a LWT up to 65 °C (08-10-12 classes).



## Floor standing unit with integrated tank

### Why choose Daikin floor standing unit with integrated domestic hot water tank?

The Daikin Altherma 3 floor standing unit is the ideal system **to deliver heating, domestic hot water and cooling** for renovation or large new built.

#### All in one system to save installation space and time

- › A combined stainless steel domestic hot water tank of 180 or 230 L and heatpump ensures a faster installation compared to traditional systems.
- › Inclusion of all hydraulic components means no third party components are required.
- › PCB board and hydraulic components are located in the front for easy access
- › Small installation footprint of 595 x 625 mm
- › Integrated back-up heater choice of 6, 9 kW models are available
- › Dedicated bi-zone models allowing temperature monitoring for 2 zones.

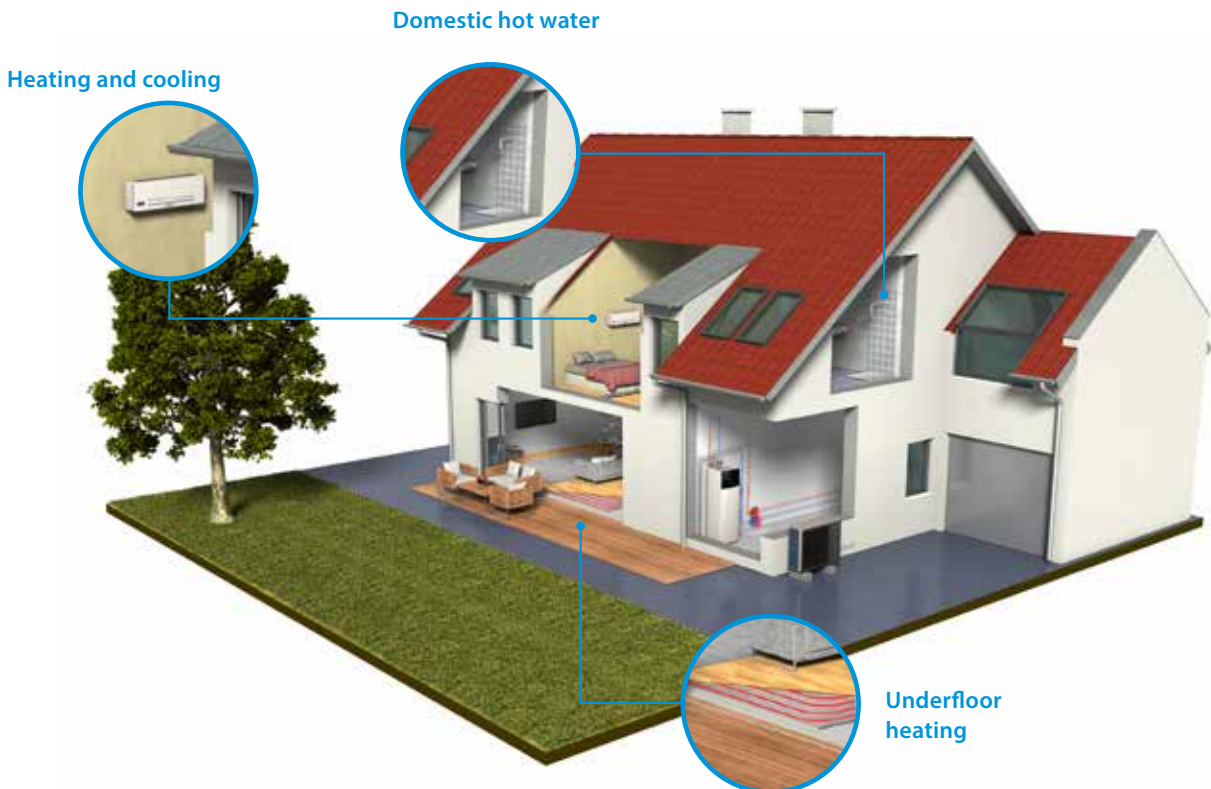

# All-in one design

## Reduces the installation footprint and height

Compared to the traditional split version for a wall mounted indoor unit and a separate domestic hot water tank, the integrated indoor unit greatly reduces the installation space required.

With a small footprint of 595 x 625 mm, the integrated indoor unit has a similar footprint when compared to other household appliances.

For installation projects, almost no side clearance is necessary as the piping is located at the top of the unit.

With an installation height of 1,65 m for an 180 L tank and 1,85 m for a 230 L tank, the required installation height is less than 2m.

The compactness of the integrated indoor unit is emphasised by its sleek design and modern look, easy blending in with other household appliances.

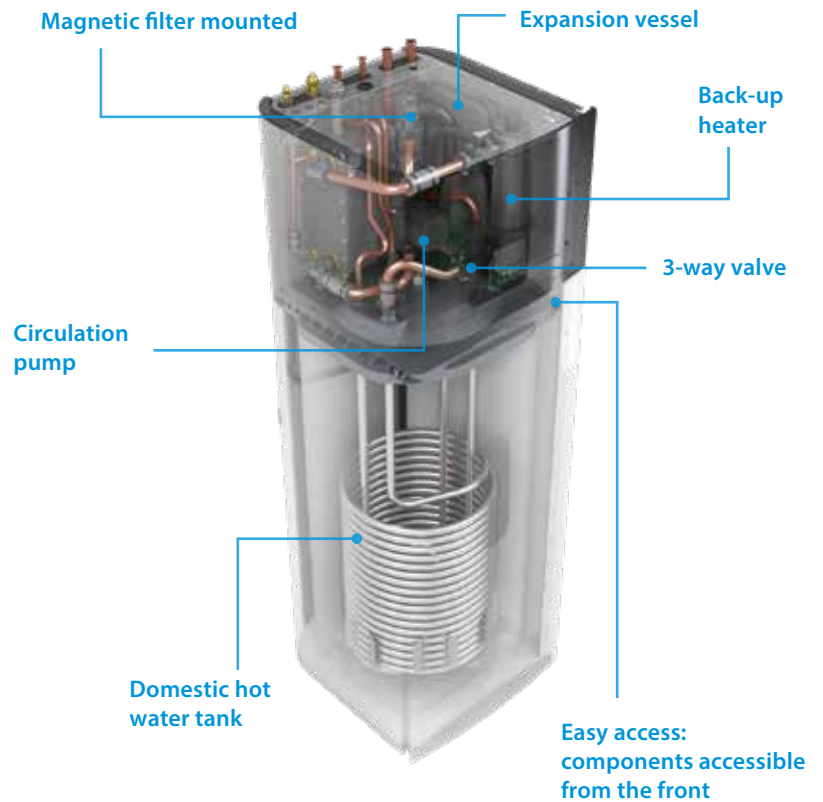

## Advanced user interface



### The Daikin Eye

The intuitive Daikin eye shows you in real time the status of your system.

Blue is perfect! Should the eye turn red, an error has occurred.

### Quick to configure

Log in and you'll be able to completely configure the unit via the new interface in less than 10 steps. You can even check if the unit is ready for use by running test cycles!

### Easy operation

Work super-fast with the new interface. It's super easy to use with just a few buttons and 2 navigational knobs.

### Beautiful design

The interface was especially designed to be very intuitive. The high contrasted colour screen delivers stunning and practical visuals that really help you as installer or service engineer.

## Integrated indoor unit





# Daikin Altherma 3 R MT

Floor standing air to water heat pump for heating and hot water, ideal for low energy houses

- › A combined stainless steel domestic hot water tank of 180 or 230L and heat pump for easy installation
- › Energy efficient heating only system based on air to water heat pump technology
- › Quick configuration in 9 steps in a high resolution colour interface wizard
- › Inclusion of all hydraulic components means no third party components are required
- › The unit's sleek design blends in with other household appliances



Efficiency data				ELVH + ERRA	12S18E6V/9W + 08EW1	12S23E6V/9W + 08EW1	12S18E6V/9W + 10EW1	12S23E6V/9W + 10EW1	12S18E6V/9W + 12EW1	12S23E6V/9W + 12EW1
Space heating	Average climate water outlet 55 °C	General	SCOP		3,42		3,43		3,53	
			ηs (Seasonal space heating efficiency)	%	134		A++		138	
	Average climate water outlet 35 °C	General	SCOP		4,81		4,84			
			ηs (Seasonal space heating efficiency)	%	190		191			
Domestic hot water heating	General	Declared load profile			L					
		Average COP	dhw		2,8	3,05	2,8	3,05	2,8	3,05
		Climate ηwh (water heating efficiency)	%		120	130	120	130	120	130
Water heating energy efficiency class					A+					
Indoor Unit				ELVH	12S18E6V/9W	12S23E6V/9W	12S18E6V/9W	12S23E6V/9W	12S18E6V/9W	12S23E6V/9W
Casing	Colour	White + Black								
	Material	Precoated sheet metal								
Dimensions	Unit	HeightxWidthxDepth	mm	1,655 x 595 x 634	1,855 x 595 x 634	1,655 x 595 x 634	1,855 x 595 x 634	1,655 x 595 x 634	1,855 x 595 x 634	
Weight	Unit		kg	120	129	120	129	120	129	
Tank	Water volume		l	180	230	180	230	180	230	
	Maximum water temperature		°C	70						
	Maximum water pressure		bar	10						
	Corrosion protection			Pickling						
Operation range	Heating	Ambient	Min.~Max.	°C	-25 ~ 25					
		Water side	Min.~Max.	°C	15 ~ 65					
	Domestic hot water	Ambient	Min.~Max.	°C	-25 ~ 35					
		Water side	Min.~Max.	°C	25 ~ 62					
Sound power level	Nom.		dBA	44						
Sound pressure level	Nom.		dBA	30						
Outdoor Unit				ERRA	08EW1	10EW1	12EW1			
Dimensions	Unit	HeightxWidthxDepth	mm	1,003 x 1,270 x 533						
Weight	Unit		kg	107						
Compressor	Quantity			1						
	Type			Hermetically sealed swing compressor						
Operation range	Heating	Min.~Max.	°CDB	-25 ~ 25						
	Cooling	Min.~Max.	°CDB	10 ~ 43						
	Domestic hot water	Min.~Max.	°CDB	-25 ~ 35						
Refrigerant	Type			R-32						
	GWP			675						
	Charge		kg	3,25						
	Charge		TCO <sub>Eq</sub>	2,19						
	Control			Expansion valve						
LW(A) Sound power level (according to EN14825)				56						
Sound pressure level Nom. (at 1 meter)				41,1						
Power supply	Name/Phase/Frequency/Voltage		Hz/V	W1/3~/50 /400						
Current	Recommended fuses		A	16						

This product contains fluorinated greenhouse gases.

# Daikin Altherma 3 R MT

Floor standing air to water heat pump for heating and hot water, ideal for low energy houses

- › A combined stainless steel domestic hot water tank of 180 or 230L and heat pump for easy installation
- › Energy efficient heating only system based on air to water heat pump technology
- › Quick configuration in 9 steps in a high resolution colour interface wizard
- › Inclusion of all hydraulic components means no third party components are required
- › The unit's sleek design blends in with other household appliances



Efficiency data				ELVH + ERRA	12S18E6V/9W + 08EV3	12S23E6V/9W + 08EV3	12S18E6V/9W + 10EV3	12S23E6V/9W + 10EV3	12S18E6V/9W + 12EV3	12S23E6V/9W + 12EV3
Space heating	Average climate water outlet 55 °C	General	SCOP	3,34						
			η <sub>s</sub> (Seasonal space heating efficiency)	130		131		135		
	Seasonal space heating eff. class	A++								
	Average climate water outlet 35 °C	General	SCOP	4,69		4,71				
			η <sub>s</sub> (Seasonal space heating efficiency)	184		186				
			Seasonal space heating eff. class	A+++						
Domestic hot water heating	General	Declared load profile			L					
	Average climate	COP	dhw	2,72	2,96	2,72	2,96	2,72	2,96	
		η <sub>wh</sub> (water heating efficiency)	%	117	126	117	126	117	126	
Water heating energy efficiency class				A+						

Indoor Unit				ELVH	12S18E6V/9W	12S23E6V/9W	12S18E6V/9W	12S23E6V/9W	12S18E6V/9W	12S23E6V/9W
Casing	Colour	White + Black								
	Material	Precoated sheet metal								
Dimensions	Unit	HeightxWidthxDepth	mm	1,655 x 595 x 634	1,855 x 595 x 634	1,655 x 595 x 634	1,855 x 595 x 634	1,655 x 595 x 634	1,855 x 595 x 634	
Weight	Unit		kg	120	129	120	129	120	129	
Tank	Water volume		l	180	230	180	230	180	230	
	Maximum water temperature		°C	70						
	Maximum water pressure		bar	10						
	Corrosion protection			Pickling						
Operation range	Heating	Ambient	Min.~Max.	°C						
		Water side	Min.~Max.	°C						
	Domestic hot water	Ambient	Min.~Max.	°C						
		Water side	Min.~Max.	°C						
Sound power level	Nom.		dBA	44						
Sound pressure level	Nom.		dBA	30						

Outdoor Unit				ERRA	08EV3	10EV3	12EV3
Dimensions	Unit	HeightxWidthxDepth	mm	1,003 x 1,270 x 533			
Weight	Unit		kg	107			
Compressor	Quantity			1			
	Type			Hermetically sealed swing compressor			
Operation range	Heating	Min.~Max.	°CDB	-25 ~ 25			
	Cooling	Min.~Max.	°CDB	10 ~ 43			
	Domestic hot water	Min.~Max.	°CDB	-25 ~ 35			
Refrigerant	Type			R-32			
	GWP			675			
	Charge		kg	3,25			
	Charge		TCO <sub>2</sub> Eq	2,19			
	Control			Expansion valve			
LW(A) Sound power level (according to EN14825)				54			
Sound pressure level Nom. (at 1 meter)				40,6			
Power supply	Name/Phase/Frequency/Voltage		Hz/V	V3/1~/50 /230			
Current	Recommended fuses		A	32			

This product contains fluorinated greenhouse gases.

# Daikin Altherma 3 R MT F

Floor standing air to water heat pump for **heating, cooling** and **hot water**, ideal for low energy houses

- › A combined stainless steel domestic hot water tank of 180 or 230L and heat pump for easy installation
- › For hot water, heating and cooling
- › Quick configuration in 9 steps in a high resolution colour interface wizard
- › Inclusion of all hydraulic components means no third party components are required
- › The unit's sleek design blends in with other household appliances



Efficiency data				ELVX + ERRA	12S18E6V/9W + 08EW1	12S23E6V/9W + 08EW1	12S18E6V/9W + 10EW1	12S23E6V/9W + 10EW1	12S18E6V/9W + 12EW1	12S23E6V/9W + 12EW1
Space heating	Average climate water outlet 55 °C	General	SCOP		3,47		3,48		3,58	
			η <sub>s</sub> (Seasonal space heating efficiency)	%	136				140	
	Average climate water outlet 35 °C	General	SCOP		4,95		4,98			
			η <sub>s</sub> (Seasonal space heating efficiency)	%	195		196			
Domestic hot water heating	General	Declared load profile			L					
		COP	dhwh		2,8	3,05	2,8	3,05	2,8	3,05
	Average climate	General	η <sub>wh</sub> (water heating efficiency)	%	120	130	120	130	120	130
			Water heating energy efficiency class			A+				
<b>Indoor Unit</b>				<b>ELVX</b>	<b>12S18E6V/9W</b>	<b>12S23E6V/9W</b>	<b>12S18E6V/9W</b>	<b>12S23E6V/9W</b>	<b>12S18E6V/9W</b>	<b>12S23E6V/9W</b>
Casing	Colour	White + Black								
	Material	Precoated sheet metal								
Dimensions	Unit	HeightxWidthxDepth	mm	1,655 x 595 x 634	1,855 x 595 x 634	1,655 x 595 x 634	1,855 x 595 x 634	1,655 x 595 x 634	1,855 x 595 x 634	
Weight	Unit		kg	120	129	120	129	120	129	
Tank	Water volume		l	180	230	180	230	180	230	
	Maximum water temperature		°C	70						
	Maximum water pressure		bar	10						
	Corrosion protection			Pickling						
Operation range	Heating	Ambient	Min.~Max.	°C	-25 ~ 25					
		Water side	Min.~Max.	°C	15 ~ 65					
	Domestic hot water	Ambient	Min.~Max.	°C	-25 ~ 35					
		Water side	Min.~Max.	°C	25 ~ 62					
Sound power level	Nom.		dB(A)	44						
Sound pressure level	Nom.		dB(A)	30						
<b>Outdoor Unit</b>				<b>ERRA</b>	<b>08EW1</b>	<b>10EW1</b>		<b>12EW1</b>		
Dimensions	Unit	HeightxWidthxDepth	mm	1,003 x 1,270 x 533						
Weight	Unit		kg	107						
Compressor	Quantity			1						
	Type			Hermetically sealed swing compressor						
Operation range	Heating	Min.~Max.	°CDB	-25 ~ 25						
	Cooling	Min.~Max.	°CDB	10 ~ 43						
	Domestic hot water	Min.~Max.	°CDB	-25 ~ 35						
Refrigerant	Type			R-32						
	GWP			675						
	Charge		kg	3,25						
	Charge		TCO <sub>Eq</sub>	2,19						
	Control			Expansion valve						
LW(A) Sound power level (according to EN14825)				56						
Sound pressure level Nom. (at 1 meter)				41,1						
Power supply	Name/Phase/Frequency/Voltage		Hz/V	W1/3~/50 /400						
Current	Recommended fuses		A	16						

This product contains fluorinated greenhouse gases.

# Daikin Altherma 3 R MT F

Floor standing air to water heat pump for **heating, cooling** and **hot water**, ideal for low energy houses

- › A combined stainless steel domestic hot water tank of 180 or 230L and heat pump for easy installation
- › For hot water, heating and cooling
- › Quick configuration in 9 steps in a high resolution colour interface wizard
- › Inclusion of all hydraulic components means no third party components are required
- › The unit's sleek design blends in with other household appliances



- 011-1W0651
- 011-1W0652
- 011-1W0653
- 011-1W0654
- 011-1W0655
- 011-1W0656

Efficiency data				ELVX + ERRA	12S18E6V/9W + 08EV3	12S23E6V/9W + 08EV3	12S18E6V/9W + 10EV3	12S23E6V/9W + 10EV3	12S18E6V/9W + 12EV3	12S23E6V/9W + 12EV3
Space heating	Average climate water outlet 55 °C	General	SCOP		3,37		3,38		3,47	
			η <sub>s</sub> (Seasonal space heating efficiency) %		132		136			
	Seasonal space heating eff. class		A++							
	Average climate water outlet 35 °C	General	SCOP		4,79	4,82				
η <sub>s</sub> (Seasonal space heating efficiency) %			188	190						
Seasonal space heating eff. class			A+++							
Domestic hot water heating	General	Declared load profile		L						
	Average climate	COP	dhw	2,72	2,96	2,72	2,96	2,72	2,96	
		η <sub>wh</sub> (water heating efficiency) %		117	126	117	126	117	126	
Water heating energy efficiency class				A+						
Indoor Unit				ELVX	12S18E6V/9W	12S23E6V/9W	12S18E6V/9W	12S23E6V/9W	12S18E6V/9W	12S23E6V/9W
Casing	Colour			White + Black						
	Material			Precoated sheet metal						
Dimensions	Unit	HeightxWidthxDepth	mm	1,655 x 595 x 634	1,855 x 595 x 634	1,655 x 595 x 634	1,855 x 595 x 634	1,655 x 595 x 634	1,855 x 595 x 634	
Weight	Unit		kg	120	129	120	129	120	129	
Tank	Water volume		l	180	230	180	230	180	230	
	Maximum water temperature		°C	70						
	Maximum water pressure		bar	10						
	Corrosion protection			Pickling						
Operation range	Heating	Ambient	Min.~Max.	°C	-25 ~25					
		Water side	Min.~Max.	°C	15 ~65					
	Domestic hot water	Ambient	Min.~Max.	°C	-25 ~35					
		Water side	Min.~Max.	°C	25 ~62					
Sound power level	Nom.		dBA	44						
Sound pressure level	Nom.		dBA	30						
Outdoor Unit				ERRA	08EV3	10EV3	12EV3			
Dimensions	Unit	HeightxWidthxDepth	mm	1,003 x 1,270 x 533						
Weight	Unit		kg	107						
Compressor	Quantity			1						
	Type			Hermetically sealed swing compressor						
Operation range	Heating	Min.~Max.	°CDB	-25 ~ 25						
	Cooling	Min.~Max.	°CDB	10 ~ 43						
	Domestic hot water	Min.~Max.	°CDB	-25 ~ 35						
Refrigerant	Type			R-32						
	GWP			675						
	Charge		kg	3,25						
	Charge		TCO <sub>Eq</sub>	2,19						
	Control			Expansion valve						
LW(A) Sound power level (according to EN14825)				54						
Sound pressure level Nom. (at 1 meter)				40,6						
Power supply	Name/Phase/Frequency/Voltage		Hz/V	V3/1~/50 /230						
Current	Recommended fuses		A	32						

This product contains fluorinated greenhouse gases.



# Daikin Altherma 3 R MT F

Floor standing unit integrated with different temperature zones management

- › A combined stainless steel domestic hot water tank of 180 or 230L and heat pump for easy installation
- › Bi-zone allows temperature monitoring for 2 zones. Connect underfloor heating to radiators to optimise efficiency
- › Quick configuration in 9 steps in a high resolution colour interface wizard
- › Inclusion of all hydraulic components means no third party components are required
- › The unit's sleek design blends in with other household appliances



Efficiency data				ELVZ + ERRA	12S18E6V/9W + 08EW1	12S23E6V/9W + 08EW1	12S18E6V/9W + 10EW1	12S23E6V/9W + 10EW1	12S18E6V/9W + 12EW1	12S23E6V/9W + 12EW1
Space heating	Average climate water outlet 55 °C	General	SCOP		3,42		3,43		3,58	
			ηs (Seasonal space heating efficiency)	%	134		134		138	
	Average climate water outlet 35 °C	General	SCOP		4,81		4,84			
			ηs (Seasonal space heating efficiency)	%	190		191			
Domestic hot water heating	General	Declared load profile			L					
		COP	dhwh		2,8	3,05	2,8	3,05	2,8	3,05
		ηwh (water heating efficiency)	%	120	130	120	130	120	130	
		Water heating energy efficiency class			A+					
Indoor Unit				ELVZ	12S18E6V/9W	12S23E6V/9W	12S18E6V/9W	12S23E6V/9W	12S18E6V/9W	12S23E6V/9W
Casing	Colour	White + Black								
	Material	Precoated sheet metal								
Dimensions	Unit	HeightxWidthxDepth	mm	1,655 x 595 x 634	1,855 x 595 x 634	1,655 x 595 x 634	1,855 x 595 x 634	1,655 x 595 x 634	1,855 x 595 x 634	
Weight	Unit		kg	133	141	133	141	133	141	
Tank	Water volume		l	180	230	180	230	180	230	
	Maximum water temperature		°C	70						
	Maximum water pressure		bar	10						
	Corrosion protection			Pickling						
Operation range	Heating	Ambient	Min.~Max.	°C	-25 ~ 25					
		Water side	Min.~Max.	°C	15 ~ 65					
	Domestic hot water	Ambient	Min.~Max.	°C	-25 ~ 35					
		Water side	Min.~Max.	°C	25 ~ 62					
Sound power level	Nom.		dBA	44						
Sound pressure level	Nom.		dBA	30						
Outdoor Unit				ERRA	08EW1	08EW1	10EW1	10EW1	12EW1	12EW1
Dimensions	Unit	HeightxWidthxDepth	mm	1,003 x 1,270 x 533						
Weight	Unit		kg	107						
Compressor	Quantity			1						
	Type			Hermetically sealed swing compressor						
Operation range	Heating	Min.~Max.	°CDB	-25 ~ 25						
	Cooling	Min.~Max.	°CDB	10 ~ 43						
	Domestic hot water	Min.~Max.	°CDB	-25 ~ 35						
Refrigerant	Type			R-32						
	GWP			675						
	Charge		kg	3,25						
	Charge		TCO,Eq	2,19						
	Control			Expansion valve						
LW(A) Sound power level (according to EN14825)				56						
Sound pressure level (at 1 meter)	Nom.			41,1						
Power supply	Name/Phase/Frequency/Voltage		Hz/V	W1/3~/50 /400						
Current	Recommended fuses		A	16						

This product contains fluorinated greenhouse gases.

# Daikin Altherma 3 R MT F

Floor standing unit integrated with different temperature zones management

- › A combined stainless steel domestic hot water tank of 180 or 230L and heat pump for easy installation
- › Bi-zone allows temperature monitoring for 2 zones. Connect underfloor heating to radiators to optimise efficiency
- › Quick configuration in 9 steps in a high resolution colour interface wizard
- › Inclusion of all hydraulic components means no third party components are required
- › The unit's sleek design blends in with other household appliances



011-IW0651  
011-IW0652  
011-IW0653  
011-IW0654  
011-IW0655  
011-IW0656

Efficiency data				ELVZ + ERRA	12S18E6V/9W + 08EV3	12S23E6V/9W + 08EV3	12S18E6V/9W + 10EV3	12S23E6V/9W + 10EV3	12S18E6V/9W + 12EV3	12S23E6V/9W + 12EV3
Space heating	Average climate water outlet 55 °C	General	SCOP	3,34						
			ηs (Seasonal space heating efficiency) %	130		131		135		
	Seasonal space heating eff. class	A++								
	Average climate water outlet 35 °C	General	SCOP	4,69		4,71				
			ηs (Seasonal space heating efficiency) %	184		186				
			Seasonal space heating eff. class	A+++						
Domestic hot water heating	General	Declared load profile		L						
		COP	dhw	2,72	2,96	2,72	2,96	2,72	2,96	
		ηwh (water heating efficiency) %		117	126	117	126	117	126	
Water heating energy efficiency class				A+						
Indoor Unit				ELVZ	12S18E6V/9W	12S23E6V/9W	12S18E6V/9W	12S23E6V/9W	12S18E6V/9W	12S23E6V/9W
Casing	Colour	White + Black								
	Material	Precoated sheet metal								
Dimensions	Unit	HeightxWidthxDepth	mm	1,655 x 595 x 634	1,855 x 595 x 634	1,655 x 595 x 634	1,855 x 595 x 634	1,655 x 595 x 634	1,855 x 595 x 634	
Weight	Unit		kg	133	141	133	141	133	141	
Tank	Water volume		l	180	230	180	230	180	230	
	Maximum water temperature		°C	70						
	Maximum water pressure		bar	10						
	Corrosion protection			Pickling						
Operation range	Heating	Ambient	Min.~Max.	°C						
		Water side	Min.~Max.	-25 ~ 25						
	Domestic hot water	Ambient	Min.~Max.	°C						
		Water side	Min.~Max.	15 ~ 65						
				-25 ~ 35						
				25 ~ 62						
Sound power level	Nom.		dBA	44						
Sound pressure level	Nom.		dBA	30						
Outdoor Unit				ERRA	08EV3	08EV3	10EV3	10EV3	12EV3	12EV3
Dimensions	Unit	HeightxWidthxDepth	mm	1,003 x 1,270 x 533						
Weight	Unit		kg	107						
Compressor	Quantity			1						
	Type			Hermetically sealed swing compressor						
Operation range	Heating	Min.~Max.	°CDB	-25 ~ 25						
	Cooling	Min.~Max.	°CDB	10 ~ 43						
	Domestic hot water	Min.~Max.	°CDB	-25 ~ 35						
Refrigerant	Type			R-32						
	GWP			675						
	Charge		kg	3,25						
	Charge		TCO <sub>Eq</sub>	2,19						
	Control			Expansion valve						
LW(A) Sound power level (according to EN14825)				54						
Sound pressure level Nom. (at 1 meter)				40,6						
Power supply	Name/Phase/Frequency/Voltage		Hz/V	V3/1~/50 /230						
Current	Recommended fuses		A	32						

This product contains fluorinated greenhouse gases.

## Floor standing unit with integrated ECH<sub>2</sub>O tank

The Daikin Altherma high temperature split integrated ECH<sub>2</sub>O is renowned for its ability to maximise renewable energy sources to provide the ultimate comfort in heating, domestic hot water and cooling

### Intelligent storage management

- › The unit is 'Smart Grid' ready to take advantage of low energy tariffs and efficiently store thermal energy for space heating and domestic hot water
- › Continuous heating during defrost mode and use of stored heat for space heating (500 L tank only)
- › Electronic management of both heat pump and ECH<sub>2</sub>O thermal store maximises energy efficiency, as well as convenient heating and domestic hot water
- › Achieves the highest standards for water sanitation
- › Uses more renewable energy with solar connection

### Innovative and high-quality tank

- › Lightweight plastic tank
- › No corrosion, anode, scale or lime deposits
- › Contains impact resistant polypropylene inner and outer walls filled with high-grade insulation foam to reduce heat losses to a minimum

### Combinable with other heat sources

- › The bivalent option allows heat from other sources such as oil, gas or pellet-fired boilers to be stored in the solar system, further lowering energy consumption

## ECH<sub>2</sub>O



### Advanced user interface

#### The Daikin-Eye

The intuitive Daikin eye shows you in real time the status of your system. Blue is perfect! Should the eye turn red, an error has occurred.

#### Quick to configure

Log in and you'll be able to completely configure the unit in less than 10 steps. You can even check if the unit is ready for use by running test cycles!

#### Easy operation

The user interface works really fast thanks to its icon-based menus.

#### Beautiful design

The interface was especially designed to be very intuitive. The high contrasted colour screen delivers stunning and practical visuals that really help you as installer or service engineer.

## ECH<sub>2</sub>O thermal store range: additional hot water comfort

Combine your indoor unit with a thermal store to achieve the ultimate comfort at home.

- › Fresh water principle: receive domestic hot water on demand while eliminating the risk of contamination and sedimentation
- › Optimal domestic hot water performance: the low temperature evolution enables high tapping performance
- › Fit for the future: possibility to integrate with renewable solar energy and other heat sources, e.g. fireplace
- › Lightweight and robust build of the unit combined with the cascade principle offers flexible installation options

Built for small and large homes, customers can choose between a pressureless and a pressurised hot water system.

### Pressureless (drain-back) solar system (ELSH\*, ELSX\*)

- › The solar collectors are only filled with water when sufficient heating is provided by the sun
- › The pumps in the control and pump unit switch on briefly and fill the collectors with storage tank water
- › After filling, water circulation is maintained by the remaining pump

### Pressurised solar system (ELSHB\*, ELSXB\*)

- › System is filled with heat transfer fluid with the correct amount of antifreeze to avoid freezing in winter
- › System is pressurised and sealed

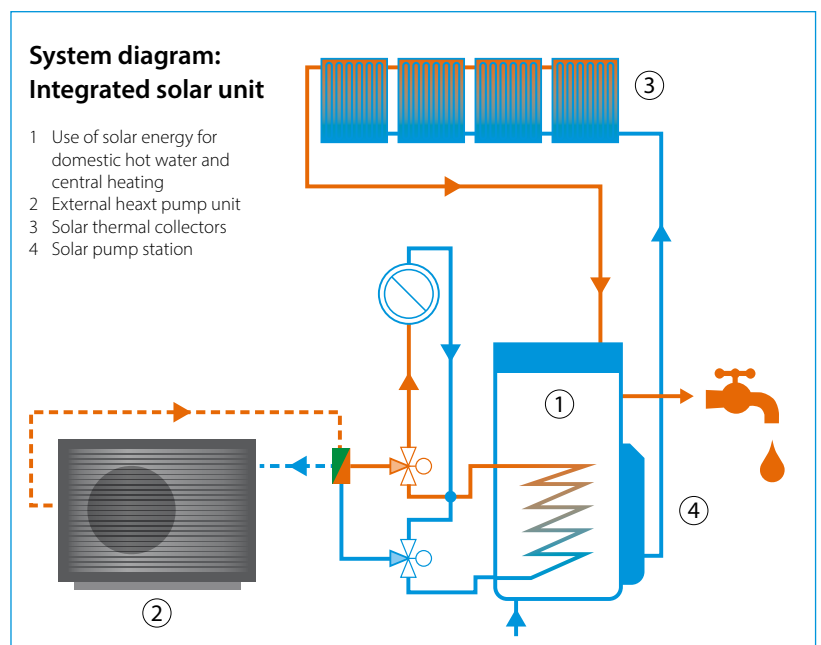
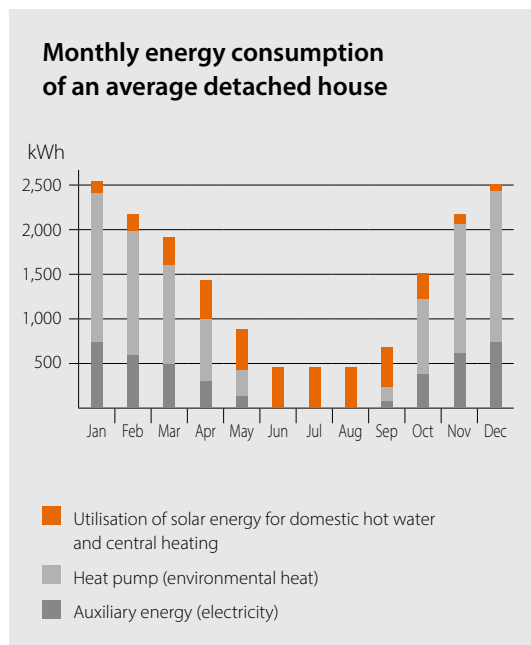



# Daikin Altherma 3 R MT ECH<sub>2</sub>O

Floor standing air-to-water heat pump for heating and hot water with thermal solar support

- › Integrated solar unit, offering top comfort in heating and hot water
- › Maintenance-free tank: no corrosion, anode, scale or lime deposits, and no loss of water through safety valve
- › Quick configuration in 9 steps in a high resolution colour interface wizard
- › Maximum use of renewable energy: uses heat pump technology for heating and solar support for space heating and domestic hot water production
- › Fresh water principle: hygienic water, with no need for thermal legionella disinfection



up to



011-1W0657  
011-1W0658

Efficiency data			ELSH + ERRA	12P30E + 08EW1	12P50E + 08EW1	12P30E + 10EW1	12P50E + 10EW1	12P30E + 12EW1	12P50E + 12EW1
Space heating	Average climate water outlet 55 °C	General	SCOP	3.42		3.43		3.53	
			ηs (Seasonal space heating efficiency) %	134				138	
			Seasonal space heating eff. class	A++					
Domestic hot water heating	Average climate water outlet 35 °C	General	SCOP	4.81		4.84			
			ηs (Seasonal space heating efficiency) %	190		191			
			Seasonal space heating eff. class	A+++					
Domestic hot water heating	Average climate water outlet 35 °C	General	Declared load profile	L	XL	L	XL	L	XL
			COP	2.83	3.29	2.83	3.29	2.83	3.29
			Water heating energy efficiency class	A+					
<b>Indoor Unit</b>			<b>ELSH</b>	<b>12P30E</b>	<b>12P50E</b>	<b>12P30E</b>	<b>12P50E</b>	<b>12P30E</b>	<b>12P50E</b>
Casing	Colour	Traffic white (RAL9016) / Traffic black (RAL9017)							
	Material	Impact resistant polypropylene							
Dimensions	Unit	HeightxWidthxDepth	mm	1,893x594x680	1,910x792x817	1,893x594x680	1,910x792x817	1,893x594x680	1,910x792x817
Weight	Unit		kg	76	91	76	91	76	91
Tank	Water volume		l	294	477	294	477	294	477
	Maximum water temperature		°C	85					
Operation range	Heating	Ambient	Min.~Max.	°C					
		Water side	Min.~Max.	°C					
	Domestic hot water	Ambient	Min.~Max.	°C					
		Water side	Min.~Max.	°C					
Sound power level	Nom.		dB(A)	44.7					
Sound pressure level	Nom.		dB(A)	36.8					
<b>Outdoor Unit</b>			<b>ERRA</b>	<b>08EW1</b>	<b>10EW1</b>	<b>12EW1</b>			
Dimensions	Unit	HeightxWidthxDepth	mm	1,003x1,270x533					
Weight	Unit		kg	107					
Compressor	Quantity			1					
	Type			Hermetically sealed swing compressor					
Operation range	Heating	Min.~Max.	°CDB	-25 ~25					
	Domestic hot water	Min.~Max.	°CDB	-25 ~35					
Refrigerant	Type			R-32					
	GWP			675					
	Charge		kg	3.25					
	Charge		TCO2Eq	2.19					
	Control			Expansion valve					
LW(A) Sound power level (according to EN14825)				56					
Sound pressure level (at 1 meter)	Nom.			41.1					
Power supply	Name/Phase/Frequency/Voltage		Hz/V	W1/3~/50 /400					
Current	Recommended fuses		A	16					

This product contains fluorinated greenhouse gases.

# Daikin Altherma 3 R MT ECH<sub>2</sub>O

Floor standing air-to-water heat pump for heating and hot water with thermal solar support

- › Integrated solar unit, offering top comfort in heating and hot water
- › Maintenance-free tank: no corrosion, anode, scale or lime deposits, and no loss of water through safety valve
- › Quick configuration in 9 steps in a high resolution colour interface wizard
- › Maximum use of renewable energy: uses heat pump technology for heating and solar support for space heating and domestic hot water production
- › Fresh water principle: hygienic water, with no need for thermal legionella disinfection



up to **A+++** **A+** **65°C** **R-32**



011-1W0657  
011-1W0658

Efficiency data				ELSH + ERRA	12P30E + 08EV3	12P50E + 08EV3	12P30E + 10EV3	12P50E + 10EV3	12P30E + 12EV3	12P50E + 12EV3
Space heating	Average climate water outlet 55 °C	General	SCOP				3.44			
			ηs (Seasonal space heating efficiency) %		130		131		135	
			Seasonal space heating eff. class				A++			
	Average climate water outlet 35 °C	General	SCOP		4.69			4.71		
		ηs (Seasonal space heating efficiency) %			184				186	
		Seasonal space heating eff. class					A+++			
Domestic hot water heating	General	Declared load profile		L	XL	L	XL	L	XL	
			COP	dhw	2.75	3.19	2.75	3.19	2.75	3.19
	Average climate	ηjwh (water heating efficiency) %		116	132	116	132	116	132	
		Water heating energy efficiency class					A+			
Indoor Unit				ELSH	12P30E	12P50E	12P30E	12P50E	12P30E	12P50E
Casing	Colour	Traffic white (RAL9016) / Traffic black (RAL9017)								
	Material	Impact resistant polypropylene								
Dimensions	Unit	HeightxWidthxDepth	mm	1,893x594x680	1,910x792x817	1,893x594x680	1,910x792x817	1,893x594x680	1,910x792x817	
Weight	Unit		kg	76	91	76	91	76	91	
Tank	Water volume		l	294	477	294	477	294	477	
	Maximum water temperature		°C	85						
Operation range	Heating	Ambient	Min.~Max.	°C						
		Water side	Min.~Max.	°C						
	Domestic hot water	Ambient	Min.~Max.	°C						
		Water side	Min.~Max.	°C						
Sound power level	Nom.		dB(A)	44.7						
Sound pressure level	Nom.		dB(A)	36.8						
Outdoor Unit				ERRA	08EV3	10EV3	12EV3			
Dimensions	Unit	HeightxWidthxDepth	mm	1,003x1,270x533						
Weight	Unit		kg	107						
Compressor	Quantity			1						
	Type			Hermetically sealed swing compressor						
Operation range	Heating	Min.~Max.	°CDB	-25 ~ 25						
	Domestic hot water	Min.~Max.	°CDB	-25 ~ 35						
Refrigerant	Type			R-32						
	GWP			675						
	Charge		kg	3.25						
	Charge		TCO2Eq	2.19						
	Control			Expansion valve						
LW(A) Sound power level (according to EN14825)				54						
Sound pressure level (at 1 meter)	Nom.			40.6						
Power supply	Name/Phase/Frequency/Voltage		Hz/V	V3/1~/50 /230						
Current	Recommended fuses		A	32						

This product contains fluorinated greenhouse gases.

# Daikin Altherma 3 R MT ECH<sub>2</sub>O

Floor standing air-to-water heat pump for bivalent heating, cooling and hot water with thermal solar support

- › Integrated solar unit, offering top comfort in heating and hot water
- › Maximum use of renewable energy: uses heat pump technology for heating and solar support for space heating and domestic hot water production
- › Fresh water principle: hygienic water, with no need for thermal legionella disinfection
- › Maintenance-free tank: no corrosion, anode, scale or lime deposits, and no loss of water through safety valve
- › Bivalent system: combinable with a secondary heat source
- › Heat loss is reduced to a minimum thanks to the high quality insulation
- › App control possible for managing heating and hot water operation



up to



011-1W0657  
011-1W0658

Efficiency data			ELSHB + ERRA	12P30E + 08EW1	12P50E + 08EW1	12P30E + 10EW1	12P50E + 10EW1	12P30E + 12EW1	12P50E + 12EW1
Space heating	Average climate water outlet 55 °C	General	SCOP	3.42		3.43		3.53	
		General	ηs (Seasonal space heating efficiency) %	134				138	
	Average climate water outlet 35 °C	General	SCOP	4.81		4.84			
		General	ηs (Seasonal space heating efficiency) %	190		191			
					A++				
Domestic hot water heating	General	Declared load profile		L	XL	L	XL	L	XL
		COP	dhw	2.83	3.29	2.83	3.29	2.83	3.29
	Average climate	rywh (water heating efficiency) %		119	136	119	136	119	136
		Water heating energy efficiency class				A+			
Indoor Unit			ELSHB	12P30E	12P50E	12P30E	12P50E	12P30E	12P50E
Casing	Colour	Traffic white (RAL9016) / Traffic black (RAL9017)							
	Material	Impact resistant polypropylene							
Dimensions	Unit	HeightxWidthxDepth	mm	1,893x594x680	1,910x792x817	1,893x594x680	1,910x792x817	1,893x594x680	1,910x792x817
Weight	Unit		kg	76	91	76	91	76	91
Tank	Water volume		l	294	477	294	477	294	477
	Maximum water temperature		°C	85					
Operation range	Heating	Ambient	Min.~Max.	°C					
		Water side	Min.~Max.	°C					
	Domestic hot water	Ambient	Min.~Max.	°C					
		Water side	Min.~Max.	°C					
Sound power level	Nom.		dBA						
Sound pressure level	Nom.		dBA						
Outdoor Unit			ERRA	08EW1	10EW1	12EW1			
Dimensions	Unit	HeightxWidthxDepth	mm	1,003x1,270x533					
Weight	Unit		kg	107					
Compressor	Quantity			1					
	Type			Hermetically sealed swing compressor					
Operation range	Heating	Min.~Max.	°CDB	-25 ~ 25					
	Domestic hot water	Min.~Max.	°CDB	-25 ~ 35					
Refrigerant	Type			R-32					
	GWP			675					
	Charge		kg	3.25					
	Charge		TCO2Eq	2.19					
	Control			Expansion valve					
LW(A) Sound power level (according to EN14825)				56					
Sound pressure level (at 1 meter)	Nom.			41.1					
Power supply	Name/Phase/Frequency/Voltage		Hz/V	W1/3~/50 /400					
Current	Recommended fuses		A	16					

This product contains fluorinated greenhouse gases.

# Daikin Altherma 3 R MT ECH<sub>2</sub>O

Floor standing air-to-water heat pump for **bivalent heating, cooling and hot water** with thermal solar support

- › Integrated solar unit, offering top comfort in heating and hot water
- › Maximum use of renewable energy: uses heat pump technology for heating and solar support for space heating and domestic hot water production
- › Fresh water principle: hygienic water, with no need for thermal legionella disinfection
- › Maintenance-free tank: no corrosion, anode, scale or lime deposits, and no loss of water through safety valve
- › Bivalent system: combinable with a secondary heat source
- › Heat loss is reduced to a minimum thanks to the high quality insulation
- › App control possible for managing heating and hot water operation



up to



Efficiency data			ELSHB + ERRA	12P30E + 08EV3	12P50E + 08EV3	12P30E + 10EV3	12P50E + 10EV3	12P30E + 12EV3	12P50E + 12EV3
Space heating	Average climate water outlet 55 °C	General	SCOP	3.44					
			ηs (Seasonal space heating efficiency) %	130					135
			Seasonal space heating eff. class	A++					
Space heating	Average climate water outlet 35 °C	General	SCOP	4.69					4.71
			ηs (Seasonal space heating efficiency) %	184					
			Seasonal space heating eff. class	A+++					
Domestic hot water heating	Average climate	General	Declared load profile	L	XL	L	XL	L	XL
			COP	2.75	3.19	2.75	3.19	2.75	3.19
			ηwh (water heating efficiency) %	116	132	116	132	116	132
Water heating energy efficiency class			A+						
Indoor Unit			ELSHB	12P30E	12P50E	12P30E	12P50E	12P30E	12P50E
Casing	Colour	Traffic white (RAL9016) / Traffic black (RAL9017)							
	Material	Impact resistant polypropylene							
Dimensions	Unit	HeightxWidthxDepth	mm	1,893x594x680	1,910x792x817	1,893x594x680	1,910x792x817	1,893x594x680	1,910x792x817
Weight	Unit		kg	76	91	76	91	76	91
Tank	Water volume		l	294	477	294	477	294	477
	Maximum water temperature		°C	85					
Operation range	Heating	Ambient	Min.~Max.	°C					
		Water side	Min.~Max.	°C					
	Domestic hot water	Ambient	Min.~Max.	°C					
		Water side	Min.~Max.	°C					
Sound power level	Nom.		dB(A)	44.7					
Sound pressure level	Nom.		dB(A)	36.8					
Outdoor Unit			ERRA	08EV3	10EV3	12EV3			
Dimensions	Unit	HeightxWidthxDepth	mm	1,003x1,270x533					
Weight	Unit		kg	107					
Compressor	Quantity			1					
	Type			Hermetically sealed swing compressor					
Operation range	Heating	Min.~Max.	°CDB	-25 ~ 25					
	Domestic hot water	Min.~Max.	°CDB	-25 ~ 35					
Refrigerant	Type			R-32					
	GWP			675					
	Charge		kg	3.25					
	Charge		TCO2Eq	2.19					
	Control			Expansion valve					
LW(A) Sound power level (according to EN14825)				54					
Sound pressure level (at 1 meter)	Nom.			40.6					
Power supply	Name/Phase/Frequency/Voltage		Hz/V	V3/1~/50 /230					
Current	Recommended fuses		A	32					

This product contains fluorinated greenhouse gases.



# Daikin Altherma 3 R MT ECH<sub>2</sub>O

Floor standing air-to-water heat pump for **heating, cooling** and **hot water** with thermal solar support

- › Integrated solar unit, offering top comfort in heating and hot water
- › Maintenance-free tank: no corrosion, anode, scale or lime deposits, and no loss of water through safety valve
- › Quick configuration in 9 steps in a high resolution colour interface wizard
- › Maximum use of renewable energy: uses heat pump technology for heating and solar support for space heating and domestic hot water production
- › Fresh water principle: hygienic water, with no need for thermal legionella disinfection



up to



Efficiency data				ELSX+ ERRA	12P30E + 08EW1	12P50E + 08EW1	12P30E + 10EW1	12P50E + 10EW1	12P30E + 10EW1	12P50E + 10EW1
Space heating	Average climate water outlet 55 °C	General	SCOP		3.47		3.48		3.48	
			ηs (Seasonal space heating efficiency) %				136			
	Seasonal space heating eff. class						A++			
	Average climate water outlet 35 °C	General	SCOP		4.95			4.98		
ηs (Seasonal space heating efficiency) %				195			196			
Seasonal space heating eff. class						A+++				
Domestic hot water heating	General	Declared load profile			L	XL	L	XL	L	XL
		COP	dhw	2.83	3.29	2.83	3.29	2.83	3.29	
	Average climate	ηwh (water heating efficiency) %		119	136	119	136	119	136	
		Water heating energy efficiency class				A+				

Indoor Unit				ELSX	12P30E	12P50E	12P30E	12P50E	12P30E	12P50E
Casing	Colour	Traffic white (RAL9016) / Traffic black (RAL9017)								
	Material	Impact resistant polypropylene								
Dimensions	Unit	HeightxWidthxDepth	mm	1,893x594x680	1,910x792x817	1,893x594x680	1,910x792x817	1,893x594x680	1,910x792x817	
Weight	Unit	kg		76	91	76	91	76	91	
	Water volume	l		294	477	294	477	294	477	
Tank	Maximum water temperature		°C	85						
	Heating	Ambient	Min.~Max.	°C	-25 ~25					
Domestic hot water		Water side	Min.~Max.	°C	15 ~65					
	Ambient	Min.~Max.	°C	-25 ~35						
Water side		Min.~Max.	°C	25 ~62						
	Sound power level	Nom.	dB(A)	44.7						
Sound pressure level	Nom.	dB(A)	36.8							

Outdoor Unit				ERRA	08EW1	10EW1	12EW1
Dimensions	Unit	HeightxWidthxDepth	mm	1,003x1,270x533			
Weight	Unit	kg		107			
Compressor	Quantity	1					
	Type	Hermetically sealed swing compressor					
Operation range	Heating	Min.~Max.	°CDB	-25 ~25			
	Domestic hot water	Min.~Max.	°CDB	-25 ~35			
Refrigerant	Type	R-32					
	GWP	675					
	Charge	kg	3.25				
	Charge	TCO2Eq	2.19				
	Control	Expansion valve					
LW(A) Sound power level (according to EN14825)	56						
Sound pressure level (at 1 meter)	41.1						
Power supply	Name/Phase/Frequency/Voltage	Hz/V	W1/3~/50 /400				
Current	Recommended fuses	A	16				

This product contains fluorinated greenhouse gases.

# Daikin Altherma 3 R MT ECH<sub>2</sub>O

Floor standing air-to-water heat pump for heating, cooling and hot water with thermal solar support

- › Integrated solar unit, offering top comfort in heating and hot water
- › Maintenance-free tank: no corrosion, anode, scale or lime deposits, and no loss of water through safety valve
- › Quick configuration in 9 steps in a high resolution colour interface wizard
- › Maximum use of renewable energy: uses heat pump technology for heating and solar support for space heating and domestic hot water production
- › Fresh water principle: hygienic water, with no need for thermal legionella disinfection



up to



Efficiency data			ELSX+ ERRA	12P30E + 08EV3	12P50E + 08EV3	12P30E + 10EV3	12P50E + 10EV3	12P30E + 12EV3	12P50E + 12EV3
Space heating	Average climate water outlet 55 °C	General	SCOP	3.37		3.38		3.47	
			ηs (Seasonal space heating efficiency) %	132				136	
			Seasonal space heating eff. class	A++					
Space heating	Average climate water outlet 35 °C	General	SCOP	4.79		4.82			
			ηs (Seasonal space heating efficiency) %	188		190			
			Seasonal space heating eff. class	A+++					
Domestic hot water heating	General	Declared load profile		L	XL	L	XL	L	XL
		COP	dhw	2.75	3.19	2.75	3.19	2.75	3.19
	Average climate	ηwh (water heating efficiency) %		116	132	116	132	116	132
		Water heating energy efficiency class		A+					
Indoor Unit			ELSX	12P30E	12P50E	12P30E	12P50E	12P30E	12P50E
Casing	Colour	Traffic white (RAL9016) / Traffic black (RAL9017)							
	Material	Impact resistant polypropylene							
Dimensions	Unit	HeightxWidthxDepth	mm	1,893x594x680	1,910x792x817	1,893x594x680	1,910x792x817	1,893x594x680	1,910x792x817
Weight	Unit		kg	76	91	76	91	76	91
Tank	Water volume		l	294	477	294	477	294	477
	Maximum water temperature		°C	85					
Operation range	Heating	Ambient	Min.~Max.	°C					
		Water side	Min.~Max.	°C					
	Domestic hot water	Ambient	Min.~Max.	°C					
		Water side	Min.~Max.	°C					
Sound power level	Nom.		dBA	44.7					
Sound pressure level	Nom.		dBA	36.8					
Outdoor Unit			ERRA	08EV3	10EV3	12EV3			
Dimensions	Unit	HeightxWidthxDepth	mm	1,003x1,270x533					
Weight	Unit		kg	107					
Compressor	Quantity			1					
	Type			Hermetically sealed swing compressor					
Operation range	Heating	Min.~Max.	°CDB	-25 ~25					
	Domestic hot water	Min.~Max.	°CDB	-25 ~35					
Refrigerant	Type			R-32					
	GWP			675					
	Charge		kg	3.25					
	Charge		TCO2Eq	2.19					
	Control			Expansion valve					
LW(A) Sound power level (according to EN14825)				54					
Sound pressure level (at 1 meter)	Nom.			40.6					
Power supply	Name/Phase/Frequency/Voltage		Hz/V	V3/1~/50 /230					
Current	Recommended fuses		A	32					

This product contains fluorinated greenhouse gases.

# Daikin Altherma 3 R MT ECH<sub>2</sub>O

Floor standing air-to-water heat pump for bivalent heating, cooling and hot water with thermal solar support

- › Integrated solar unit, offering top comfort in heating and hot water
- › Maximum use of renewable energy: uses heat pump technology for heating and solar support for space heating and domestic hot water production
- › Fresh water principle: hygienic water, with no need for thermal legionella disinfection
- › Maintenance-free tank: no corrosion, anode, scale or lime deposits, and no loss of water through safety valve
- › Bivalent system: combinable with a secondary heat source
- › Heat loss is reduced to a minimum thanks to the high quality insulation
- › App control possible for managing heating and hot water operation



up to



Efficiency data				ELSX-B + ERRA	12P30E + 08EW1	12P50E + 08EW1	12P30E + 10EW1	12P50E + 10EW1	12P30E + 10EW1	12P50E + 10EW1
Space heating	Average climate water outlet 55 °C	General	SCOP	3.47		3.48		3.48		
			η <sub>s</sub> (Seasonal space heating efficiency) %	136		136				
	Seasonal space heating eff. class			A++						
	Average climate water outlet 35 °C	General	SCOP	4.95		4.98		4.98		
η <sub>s</sub> (Seasonal space heating efficiency) %			195		196					
Seasonal space heating eff. class			A+++							
Domestic hot water heating	General	Declared load profile		L	XL	L	XL	L	XL	
		COP	dhw	2.83	3.29	2.83	3.29	2.83	3.29	
	Average climate	η <sub>wh</sub> (water heating efficiency) %		119	136	119	136	119	136	
		Water heating energy efficiency class		A+						
Indoor Unit				ELSX-B	12P30E	12P50E	12P30E	12P50E	12P30E	12P50E
Casing	Colour			Traffic white (RAL9016) / Traffic black (RAL9017)						
	Material			Impact resistant polypropylene						
Dimensions	Unit	HeightxWidthxDepth		mm	1,893x594x680	1,910x792x817	1,893x594x680	1,910x792x817	1,893x594x680	1,910x792x817
Weight	Unit			kg	76	91	76	91	76	91
Tank	Water volume			l	294	477	294	477	294	477
	Maximum water temperature			°C	85					
Operation range	Heating	Ambient	Min.~Max.	°C	-25 ~25					
		Water side	Min.~Max.	°C	15 ~65					
	Domestic hot water	Ambient	Min.~Max.	°C	-25 ~35					
		Water side	Min.~Max.	°C	25 ~62					
Sound power level	Nom.			dBA	44.7					
Sound pressure level	Nom.			dBA	36.8					
Outdoor Unit				ERRA	08EW1	10EW1	12EW1			
Dimensions	Unit	HeightxWidthxDepth		mm	1,003x1,270x533					
Weight	Unit			kg	107					
Compressor	Quantity				1					
	Type				Hermetically sealed swing compressor					
Operation range	Heating	Min.~Max.		°CDB	-25 ~25					
	Domestic hot water	Min.~Max.		°CDB	-25 ~35					
Refrigerant	Type				R-32					
	GWP				675					
	Charge			kg	3.25					
	Charge			TCO2Eq	2.19					
	Control				Expansion valve					
LW(A) Sound power level (according to EN14825)					56					
Sound pressure level (at 1 meter)	Nom.				41.1					
Power supply	Name/Phase/Frequency/Voltage			Hz/V	W1/3~/50 /400					
Current	Recommended fuses			A	16					

This product contains fluorinated greenhouse gases.

# Daikin Altherma 3 R MT ECH<sub>2</sub>O

Floor standing air-to-water heat pump for bivalent heating, cooling and hot water with thermal solar support

- › Integrated solar unit, offering top comfort in heating and hot water
- › Maximum use of renewable energy: uses heat pump technology for heating and solar support for space heating and domestic hot water production
- › Fresh water principle: hygienic water, with no need for thermal legionella disinfection
- › Maintenance-free tank: no corrosion, anode, scale or lime deposits, and no loss of water through safety valve
- › Bivalent system: combinable with a secondary heat source
- › Heat loss is reduced to a minimum thanks to the high quality insulation
- › App control possible for managing heating and hot water operation



up to



Efficiency data				ELSX-B+ ERRA	12P30E + 08EV3	12P50E + 08EV3	12P30E + 10EV3	12P50E + 10EV3	12P30E + 12EV3	12P50E + 12EV3
Space heating	Average climate water outlet 55 °C	General	SCOP		3.37		3.38		3.47	
			ηs (Seasonal space heating efficiency) %		132		136			
	Seasonal space heating eff. class			A++						
	Average climate water outlet 35 °C	General	SCOP		4.79		4.82			
ηs (Seasonal space heating efficiency) %				188		190				
Seasonal space heating eff. class			A+++							
Domestic hot water heating	General	Declared load profile		L	XL	L	XL	L	XL	
		COP	dhw	2.75	3.19	2.75	3.19	2.75	3.19	
	Average climate	rywh (water heating efficiency) %		116	132	116	132	116	132	
		Water heating energy efficiency class		A+						
Indoor Unit				ELSX-B	12P30E	12P50E	12P30E	12P50E	12P30E	12P50E
Casing	Colour	Traffic white (RAL9016) / Traffic black (RAL9017)								
	Material	Impact resistant polypropylene								
Dimensions	Unit	HeightxWidthxDepth	mm	1,893x594x680	1,910x792x817	1,893x594x680	1,910x792x817	1,893x594x680	1,910x792x817	
Weight	Unit		kg	76	91	76	91	76	91	
Tank	Water volume		l	294	477	294	477	294	477	
	Maximum water temperature		°C	85						
Operation range	Heating	Ambient	Min.~Max.	°C						
		Water side	Min.~Max.	°C						
	Domestic hot water	Ambient	Min.~Max.	°C						
		Water side	Min.~Max.	°C						
Sound power level	Nom.		dBA	44.7						
Sound pressure level	Nom.		dBA	36.8						
Outdoor Unit				ERRA	08EV3	10EV3	12EV3			
Dimensions	Unit	HeightxWidthxDepth	mm	1,003x1,270x533						
Weight	Unit		kg	107						
Compressor	Quantity			1						
	Type			Hermetically sealed swing compressor						
Operation range	Heating	Min.~Max.	°CDB	-25 ~25						
	Domestic hot water	Min.~Max.	°CDB	-25 ~35						
Refrigerant	Type			R-32						
	GWP			675						
	Charge		kg	3.25						
	Charge		TCO2Eq	2.19						
	Control			Expansion valve						
LW(A) Sound power level (according to EN14825)				54						
Sound pressure level (at 1 meter)	Nom.			40.6						
Power supply	Name/Phase/Frequency/Voltage		Hz/V	V3/1~/50 /230						
Current	Recommended fuses		A	32						

This product contains fluorinated greenhouse gases.

# Wall mounted unit

## Why choose Daikin wall mounted unit?

The Daikin Altherma 3 split wall mounted unit offers heating and cooling with high flexibility for a quick and easy installation, with an optional connection to deliver domestic hot water.

### High flexibility for installation and domestic hot water connection

- › Inclusion of all hydraulic components means no third party components are required
- › PCB board and hydraulic components are located in the front for easy access
- › Compact dimensions allows for small installation space, as almost no side clearances are required
- › The unit's sleek design blends in with other household appliances
- › Combine with a stainless steel or ECH<sub>2</sub>O thermal store

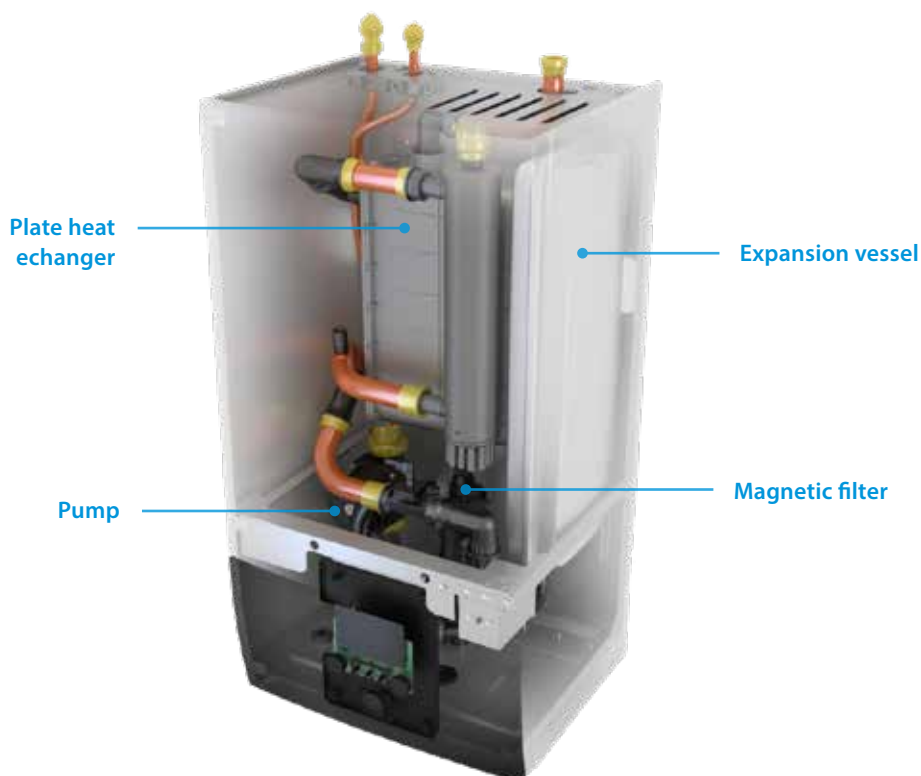



## Flexibility in providing domestic hot water

If the end user requires hot water and installation height is limited, a separate stainless steel tank provides the required installation flexibility.

ECH<sub>2</sub>O thermal store range: additional hot water comfort

Combine your wall mounted unit with a thermal store for additional hot water comfort.

- › Fresh water principle: receive domestic hot water on demand while eliminating the risk of contamination and sedimentation
- › Optimal domestic hot water performance: with high tapping performance
- › Fit for future possibility to integrate with renewable solar energy and other heat sources, e.g. fireplace
- › Lightweight and robust build on the unit combined with cascade principle offers flexible installation options



## Flexibility in providing space heating

The wall mounted unit is the perfect choice in case the end user is looking for space heating or cooling while domestic hot water is provided by another system.

Example of installation with a stainless steel domestic hot water tank.

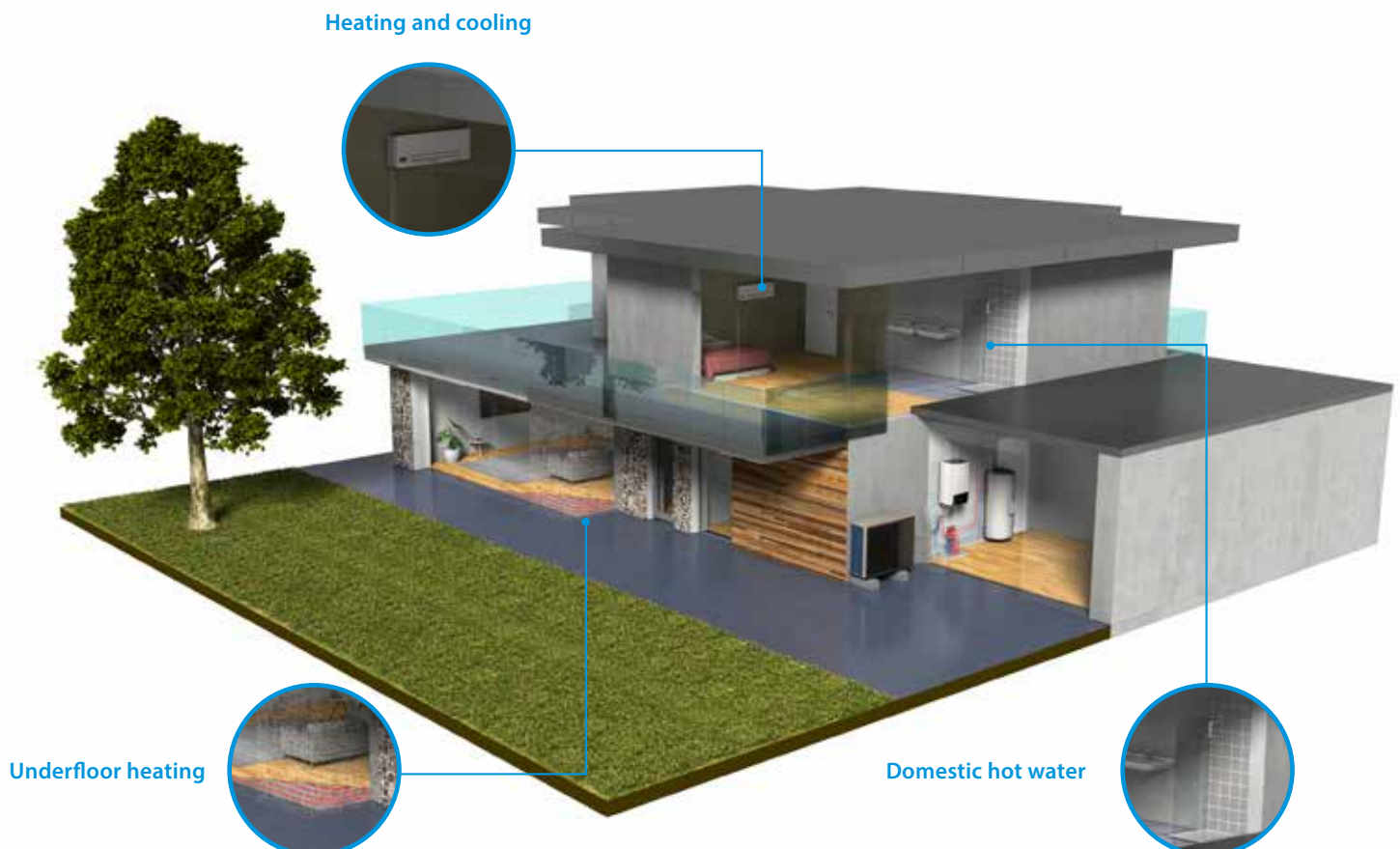

# Daikin Altherma 3 R MT W

Wall mounted **heating only** air to water heat pump

- › Quick configuration in 9 steps in a high resolution colour interface wizard
- › Compact dimensions allows for small installation space, as almost no side clearances are required.
- › Combine with a stainless steel tank or ECH<sub>2</sub>O thermal store.
- › Inclusion of all hydraulic components means no third party components are required
- › The unit's sleek design blends in with other household appliances



up to **A+++** **R-32**



011-1W0651  
011-1W0653  
011-1W0655

Efficiency data				ELBH + ERRA	12E6V/9W + 08EW1	12E6V/9W + 08EV3	12E6V/9W + 10EW1	12E6V/9W + 10EV3	12E6V/9W + 12EW1	12E6V/9W + 12EV3
Space heating	Average climate water outlet 55 °C	General	SCOP	3,42	3,42	3,42	3,42	3,42	3,42	3,42
			ηs (Seasonal space heating efficiency) %	134	130	134	131	138	135	
	Average climate water outlet 35 °C	General	SCOP	4,81	4,69	4,84	4,71	4,84	4,71	
			ηs (Seasonal space heating efficiency) %	190	184	191	186	191	186	
				Seasonal space heating eff. class	A++	A++	A++	A++	A++	A++
				Seasonal space heating eff. class	A+++	A+++	A+++	A+++	A+++	A+++
Indoor Unit				ELBH	12E6V	12E9W	12E6V	12E9W	12E6V	12E9W
Casing	Colour				White + Black					
	Material				Resin, sheet metal					
Dimensions	Unit	HeightxWidthxDepth		mm	840 x 440 x 390					
Weight	Unit			kg	48,5					
Operation range	Heating	Ambient	Min.~Max.	°C	-25 ~ 25					
		Water side	Min.~Max.	°C	15 ~ 65					
	Domestic hot water	Ambient	Min.~Max.	°C	-25 ~ 35					
		Water side	Min.~Max.	°C	25 ~ 62					
Sound power level	Nom.			dBA	44					
Sound pressure level	Nom.			dBA	30					
Outdoor Unit				ERRA	08EW1	08EV3	10EW1	10EV3	12EW1	12EV3
Dimensions	Unit	HeightxWidthxDepth		mm	1,003 x 1,270 x 533					
Weight	Unit			kg	107					
Compressor	Quantity				1					
	Type				Hermetically sealed swing compressor					
Operation range	Heating	Min.~Max.		°CDB	-25 ~ 25					
	Domestic hot water	Min.~Max.		°CDB	-25 ~ 35					
Refrigerant	Type				R-32					
	GWP				675					
	Charge			kg	3,25					
	Charge			TCO <sub>Eq</sub>	2,19					
Control					Expansion valve					
LW(A) Sound power level (according to EN14825)					56	54	56	54	56	54
Sound pressure level Nom. (at 1 meter)					41,1	40,6	41,1	40,6	41,1	40,6
Power supply	Name/Phase/Frequency/Voltage			Hz/V	W1/3~/50 /400	V3/1~/50 /230	W1/3~/50 /400	V3/1~/50 /230	W1/3~/50 /400	V3/1~/50 /230
Current	Recommended fuses			A	16	32	16	32	16	32

This product contains fluorinated greenhouse gases.

# Daikin Altherma 3 R MT W

Wall mounted **reversible** air to water heat pump for heating and cooling

- › Quick configuration in 9 steps in a high resolution colour interface wizard
- › Compact dimensions allows for small installation space, as almost no side clearances are required.
- › Combine with a stainless steel tank or ECH<sub>2</sub>O thermal store.
- › Inclusion of all hydraulic components means no third party components are required
- › The unit's sleek design blends in with other household appliances



up to



Efficiency data				ELBX + ERRA	12E6V/9W + 08EW1	12E6V/9W + 08EV3	12E6V/9W + 10EW1	12E6V/9W + 10EV3	12E6V/9W + 12EW1	12E6V/9W + 12EV3
Space heating	Average climate water outlet 55 °C	General	SCOP	3,47	3,37	3,48	3,38	3,58	3,47	
			η <sub>s</sub> (Seasonal space heating efficiency)	136	132	136	132	140	136	
	Average climate water outlet 35 °C	General	SCOP	4,95	4,79	4,98	4,82	4,98	4,82	
			η <sub>s</sub> (Seasonal space heating efficiency)	195	188	196	190	196	190	
				Seasonal space heating eff. class						
				A++						
				A+++						
Indoor Unit				ELBX	12E6V	12E9W	12E6V	12E9W	12E6V	12E9W
Casing	Colour			White + Black						
	Material			Resin, sheet metal						
Dimensions	Unit	HeightxWidthxDp		mm						
Weight	Unit			kg						
Operation range	Heating	Ambient	Min.~Max.	°C						
		Water side	Min.~Max.	°C						
	Domestic hot water	Ambient	Min.~Max.	°C						
		Water side	Min.~Max.	°C						
Sound power level	Nom.			dBA						
Sound pressure level	Nom.			dBA						
Outdoor Unit				ERRA	08EW1	08EV3	10EW1	10EV3	12EW1	12EV3
Dimensions	Unit	HeightxWidthxDp		mm						
Weight	Unit			kg						
Compressor	Quantity			1						
	Type			Hermetically sealed swing compressor						
Operation range	Heating	Min.~Max.		°CDB						
	Domestic hot water	Min.~Max.		°CDB						
Refrigerant	Type			R-32						
	GWP			675						
	Charge			kg						
	Charge			TCO <sub>Eq</sub>						
				Expansion valve						
LW(A) Sound power level (according to EN14825)				56	54	56	54	56	54	
Sound pressure level (at 1 meter)	Nom.			41,1	40,6	41,1	40,6	41,1	40,6	
Power supply	Name/Phase/Frequency/Voltage			Hz/V	W1/3~/50 /400	V3/1~/50 /230	W1/3~/50 /400	V3/1~/50 /230	W1/3~/50 /400	V3/1~/50 /230
Current	Recommended fuses			A	16	32	16	32	16	32

This product contains fluorinated greenhouse gases.







# Thermal stores and tanks

## Hot water heating installation options

### Why choose a thermal store or domestic hot water tank?

Whether you only need hot water or you want to combine your hot water with solar systems, we offer you the best solutions to the highest levels of comfort, energy efficiency and reliability.



Thermal store



Stainless steel tank



### Domestic hot water tanks

#### Stainless steel tanks

##### Comfort

- › EKHWS(P)(U)-D: available in 150, 180, 200, 250 and 300 litres in stainless steel

##### Efficiency

- › High-quality insulation keeps heat loss to a minimum
- › Efficient temperature heating: from 10 °C to 50 °C in only 60 minutes
- › Available as an integrated solution or separate tank

##### Reliability

- › At necessary intervals, the unit can heat up water up to 60 °C to prevent the risk of bacteria growth





# The ECH<sub>2</sub>O thermal store range

## ECH<sub>2</sub>O thermal store: additional hot water comfort

Combine your monobloc with a thermal store to achieve the ultimate comfort at home.

- › Fresh water principle: receive domestic hot water on demand while eliminating the risk of contamination and sedimentation
- › Optimal domestic hot water performance: the low temperature evolution enables high tapping performance
- › Fit for the future: possibility to integrate with renewable solar energy and other heat sources, e.g. fireplace
- › Lightweight and robust build of the unit combined with the cascade principle offers flexible installation options

Built for small and large homes, customers can choose between a pressureless and a pressurised hot water system.

## Efficiency

- › Fit for the future: maximise renewable energy sources
- › Intelligent Heat Storage Management: ensures continuous heating during defrost mode, and uses stored heat for space heating
- › High-quality insulation keeps heat loss to a minimum

## Reliability

- › Maintenance-free tank: no corrosion, anode, scale or lime deposits, and no water loss through the safety valve

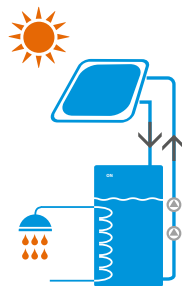

Drain-back solar system

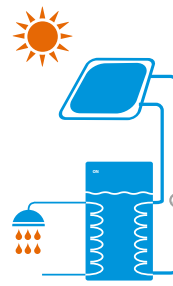

Pressurised solar system

## Pressureless (drain-back) solar system

- › The solar collectors are only filled with water when sufficient heating is provided by the sun
- › The pumps in the control and pump unit switch on briefly and fill the collectors with storage tank water
- › After filling, water circulation is maintained by the remaining pump

## Pressurised solar system

- › System is filled with heat transfer fluid with the correct amount of antifreeze to avoid freezing in winter
- › System is pressurised and sealed

## Monthly energy consumption of an average detached house

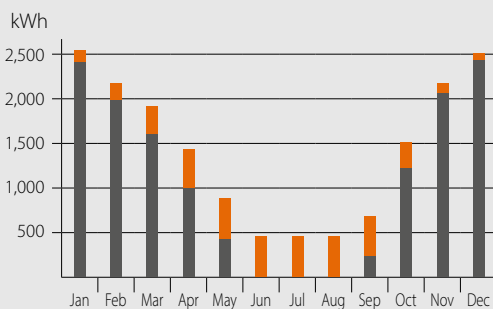

- Utilisation of solar energy for domestic hot water and central heating
- Heat pump (environmental heat)
- Auxiliary energy (electricity)

## System diagram: Integrated solar unit

- 1 Use of solar energy for domestic hot water and central heating
- 2 External heat pump unit
- 3 Solar thermal collectors
- 4 Solar pump station

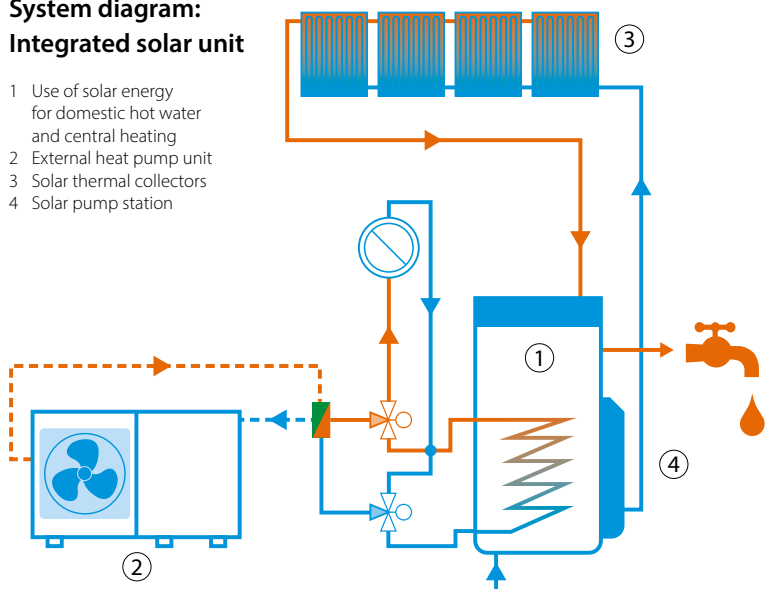

# Thermal store

## Plastic domestic hot water tank with solar support

- › Tank designed for connection with pressurised thermal solar system
- › Tank designed for connection with drainback thermal solar system
- › Available in 300 and 500 liters
- › Large hot water storage tank to provide domestic hot water at any time
- › Heat loss is reduced to a minimum thanks to the high quality insulation
- › Space heating support possible (500 L tank only)



Accessory		EKHWP	300B	500B	300PB	500PB	
Casing	Colour	Traffic white (RAL9016) / Dark grey (RAL7011)					
	Material	Impact resistant polypropylene					
Dimensions	Unit	Width	mm	595	790	595	790
		Depth	mm	615	790	615	790
Weight	Unit	Empty	kg	58	82	58	89
	Tank	Water volume	l	294	477	294	477
Heat exchanger	Material		Polypropylen				
	Maximum water temperature		°C	85			
	Insulation	Heat loss	kWh/24h	1.5	1.7	1.5	1.7
	Energy efficiency class			B			
	Standing heat loss		W	64	72	64	72
	Storage volume		l	294	477	294	477
Heat exchanger	Domestic hot water	Quantity		1			
		Tube material		Stainless steel (DIN 1.4404)			
		Face area	m²	5,600	5,800	5,600	5,900
		Internal coil volume	l	27.1	28.1	27.1	28.1
		Operating pressure	bar	6			
	Average specific thermal output		W/K	2,790	2,825	2,790	2,825
	Charging	Quantity		1			
		Tube material		Stainless steel (DIN 1.4404)			
		Face area	m²	3	4	3	4
		Internal coil volume	l	13	18	13	18
		Operating pressure	bar	3			
	Average specific thermal output		W/K	1,300	1,800	1,300	1,800
	Pressurised solar	Average specific thermal output		W/K	-	390	840
	Auxiliary solar heating	Tube material		-	Stainless steel (DIN 1.4404)	-	Stainless steel (DIN 1.4404)
Face area		m²	-	1	-	1	
Internal coil volume		l	-	4	-	4	
Operating pressure		bar	-	3	-	3	
Average specific thermal output		W/K	-	280	-	280	

# Domestic hot water tank

## Stainless steel domestic hot water tank

- › Available in 150, 180, 200, 250 and 300 litres
- › Stainless steel domestic hot water tank



EKHWS(U)-D



Accessory		EKHWSU/EKHWS/EKHWS	150D3V3	180D3V3	200D3V3	250D3V3	300D3V3	150D3V3	180D3V3	200D3V3	250D3V3	300D3V3
Casing	Colour		Neutral white									
	Material		Epoxy coated steel / Epoxy-coated mild steel									
Tank	Water volume	l	145	174	192	242	292	145	174	192	242	292
	Material		Stainless steel (EN 1.4521)									
	Maximum water temperature	°C	75									
	Insulation Heat loss	kWh/24h	1.1 (1)	1.2 (1)	1.3 (1)	1.4 (1)	1.6 (1)	1.1 (1)	1.2 (1)	1.3 (1)	1.4 (1)	1.6 (1)
Heat exchanger	Energy efficiency class		B									
	Domestic hot water	Quantity	1									
		Tube material		Stainless steel (EN 1.4521)								
	Face area	m <sup>2</sup>	1.050	1.400		1.800		1.050	1.400		1.800	
	Internal coil volume	l	4.9	6.5		8.2		4.9	6.5		8.2	
Booster heater	Operating pressure	bar	10									
	Capacity	kW	3									
Power supply	Phase/Frequency/Voltage	Hz/V	1~/50/230									
Weight	Unit Empty	kg	45 - 45	50 - 50	53 - 53	58 - 58	63 - 63	45 - 45	50 - 50	53 - 53	58 - 58	63 - 63
Tank-Weight	Standing Unit	S - Empty heat loss W - kg	45 - 45	50 - 50	55 - 53	60 - 58	68 - 63	45 - 45	50 - 50	55 - 53	60 - 58	68 - 63
	Storage Unit	V - Empty volume l - kg	145 - 45	174 - 50	192 - 53	242 - 58	292 - 63	145 - 45	174 - 50	192 - 53	242 - 58	292 - 63

(1) Heat loss according to EN12897

# Daikin Altherma HPC Floor standing model



The floor standing heat pump convector impresses with its low sound operations, and its slim design that received the RedDot Award 2020. Next to heating and cooling, the unit can also provide indoor air quality control.

## Why Indoor Air Quality Matters

Indoor Air Quality (IAQ) refers to the air quality in a building or structure, breathed in every day by the building's occupants.

When planning new residential buildings, schools, offices or light commercial buildings, many things must be considered. Besides structural factors, there are also the topics of heating, cooling and something often neglected: indoor air quality.

Did you know that the indoor air we breathe, whether at home, at the office, or in a hotel room could in fact be much more polluted than the air outside?

- › 90 % of our lives is spent indoors
- › Indoor air quality can be 2 to 5 times worse than outdoor air quality because of pollutants, such as pollen, bacteria, etc.



## How does Daikin Altherma HPC ensure a healthy and comfortable indoor air quality?

When a pollutant level of indoor air is reached, the IAQ sensor opens a damper, which allows fresh air to come in. The incoming fresh air is immediately heated or cooled (depending on the demand) by the heat pump convector. In this way the indoor air remains of good quality while comfort is ensured.

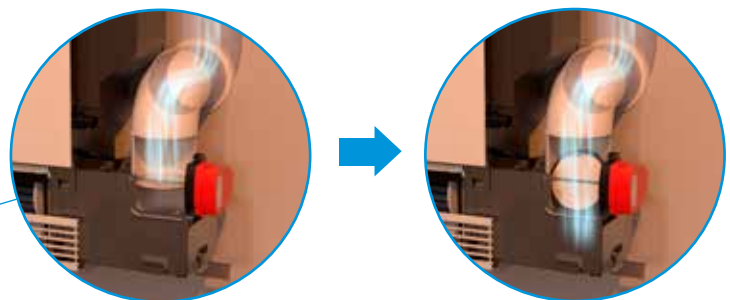
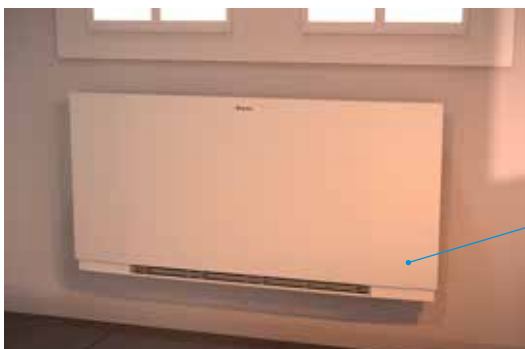



## Slim design



The floor standing Daikin Altherma HPC has a depth of only 135 mm that fits any house or apartment. Its optimised design was rewarded with the Reddot Design Award 2020.

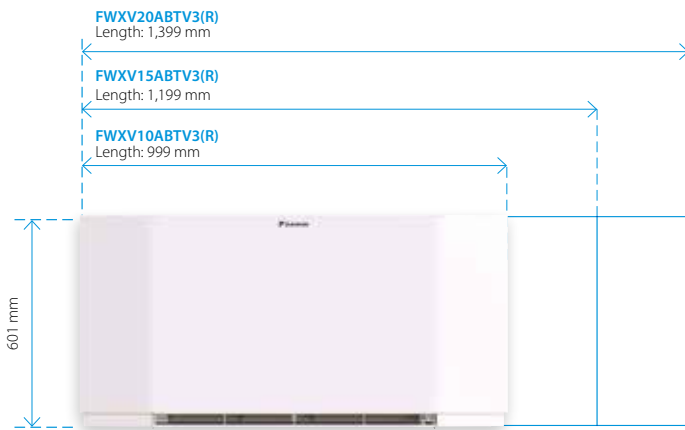

## Fast and high capacity

The Daikin Altherma HPC combines the advantages of residential underfloor heating and radiators. It delivers high-capacity heating or cooling faster and can be set at ultra-low temperatures (35/30 °C regime).



## Discreet

As the unit reaches its set point, a continuous modulating fan gradually reduces its speed and creates less noise. For the wall mounted and concealed units, the sound pressure measures 25dB(A) at 1m when the fan is on low-speed setting. Even lower sound pressure in super-silent mode (night mode).

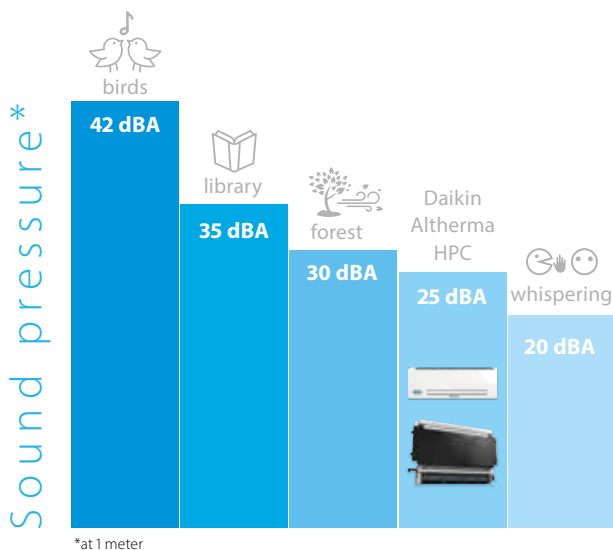

## Controls

Daikin offers a wide variety of controllers that are functional and have a great design.

### EKRTCTRL1



- > Built-in controller
- > Fully modulating
- > Multicolor display

### EKRTCTRL2



- > Built-in controller
- > 4 speed settings

### EKWHCTRL1



- > Wall controller
- > Fully modulating
- > In combination with EKWHCTRL0

### EKPCBO



- > Built-in controller
- > ON/OFF
- > In combination with external thermostats

### EKWHCTRL1A



- > Wall controller
- > Fully modulating
- > In combination with EKWHCTRL0
- > Includes indoor air quality sensor



Thanks to its slim design, our wall-mounted unit blends in with your interior discreetly while helping you save valuable floor space.

## Slim design

Daikin Altherma HPC is a compact unit made of a design metal casing including all valves.

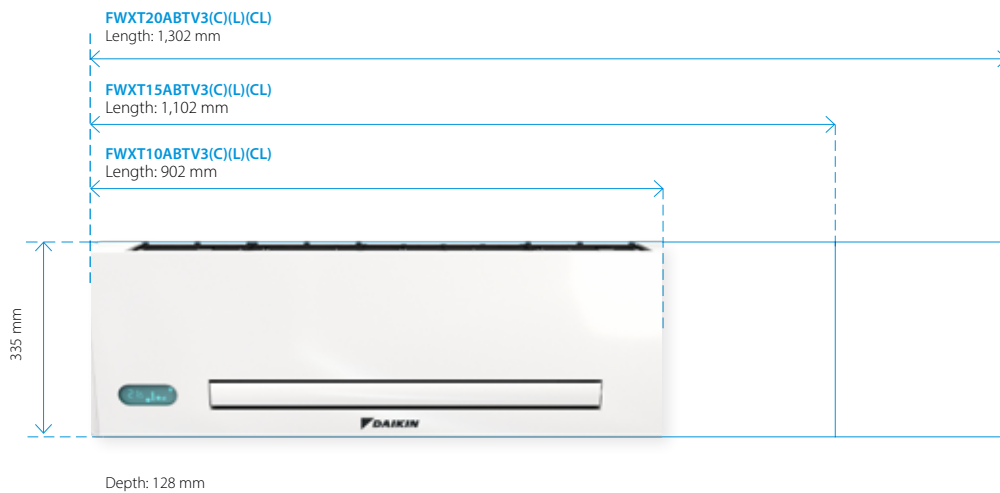

## Controls

Choice of:

- > Fully modulating controller allowing for remote control of the unit.
- > Infrared remote controller and on-board touch panel.

### EKWHCTRL1



- > Wall controller
- > Fully modulating
- > For models FWXT-ABTV3(L)

### Infrared remote controller



- > Remote
- > Fully modulating
- > For models FWXT-ABTV3C(L)

## Compactness



- 1 Slim depth**  
The depth of 128 mm is an outstanding technical achievement that ensures a perfect fit in any home.
- 2 More space for valves**  
Ease of installation: the space for hydraulic valves is wide and easily accessible.

- 3 Modulated airflow**  
When there is less heating demand, the unit modulates its airflow to slow down the fan rate, and in the process, lowers the operational sound.





Forget about your heating or cooling installation altogether: our concealed model vanishes into the wall or ceiling for visual comfort while preserving its unique heating and cooling capabilities.

## Slim design

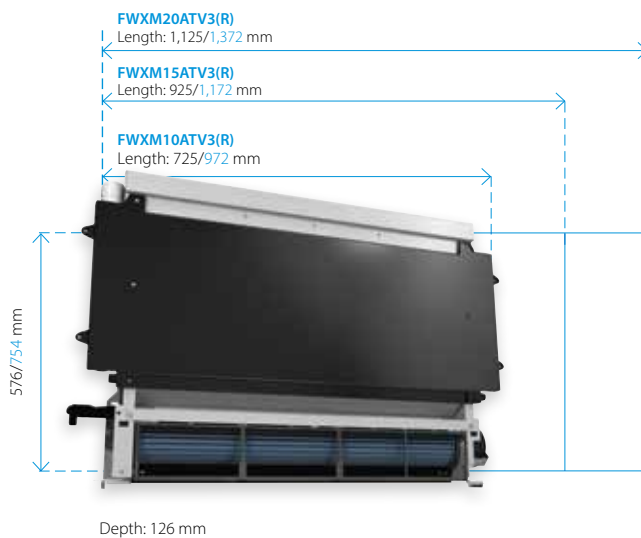

Blue dimensions are for the front cover.

## Controls

### EKWHCTRL1



- > Wall controller
- > Fully modulating
- > In combination with EKWHCTRL0

## Flexible installation

Daikin Altherma HPC can be installed in four different ways, allowing you to install it in almost all conditions. The unit can be positioned horizontally or vertically. For horizontal, in-ceiling installation, three different possibilities are offered:

- > Horizontal cover panel and vertical grille for air outlet
- > Horizontal intake grille and vertical grille for air outlet
- > Horizontal intake and outlet grilles









# Onecta App

Now available with voice control

The Onecta App is for those who live their life on the go and who want to manage their heating system from their smartphone.



# onecta

**NEW**

## Voice control

To provide users with even more comfort and ease, the Onecta App now offers voice control. This hands-free feature cuts down on clicks to manage units faster than ever before.

Cross-functional and multilingual, voice control pairs well with any smart device, including Google Assistant and Amazon Alexa.

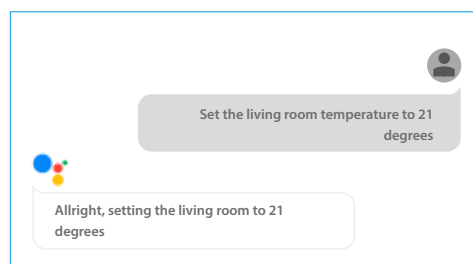

Example of using the voice control via Google Assistant

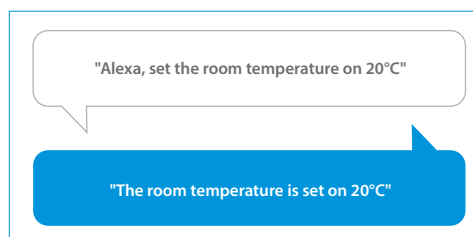

Example of using the voice control via Amazon Alexa

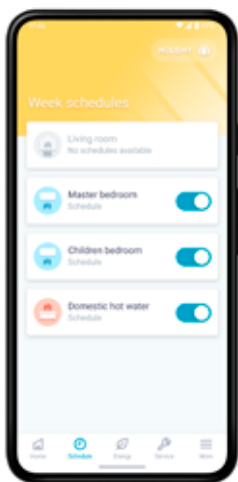

## Schedule

Set up a programme outlining when the system should operate, and create up to six actions per day.

- Schedule room temperature and operation mode
- Enable holiday mode to save costs

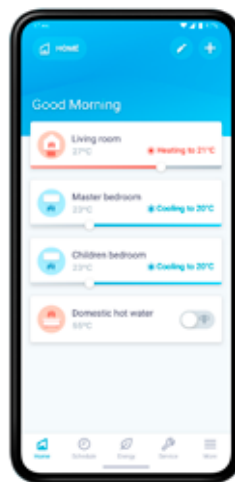

## Control

Customise the system to fit your lifestyle and year-round comfort levels.

- Change room and domestic hot water temperature
- Turn on powerful mode to boost hot water production



## Monitor

Receive a thorough overview of how the system is performing and how much energy it consumes.

- Check the status of the heating system
- Access energy consumption graphs (day, week, month)

Function availability depends on the system type, configuration and operation mode. The app functionality is only available if both the Daikin system and the app have a reliable internet connection.



Scan the QR code to download the app now





# User-friendly wired remote controller with premium design

Madoka. The beauty of simplicity

Madoka



**Black**  
RAL 9005 (matt)  
BRC1HHDK



**White**  
RAL9003 (glossy)  
BRC1HHDW



**Silver**  
RAL 9006 (metallic)  
BRC1HHDS

## Madoka combines refinement and simplicity

- > Sleek and elegant design
- > Intuitive touch-button control
- > Three colours to match any interior
- > Compact: measures only 85 x 85 mm

## Easy update via Bluetooth

It is strongly recommended to make sure that the user interface is up to date. To update the software or check if updates are available, all you need is a mobile device and the Madoka Assistant app. The app is available on Google Play and in the App Store.



## Award-winning design

Madoka received an IF Design Award and Reddot Product Design Award for its innovative design. These awards represent two of the most prestigious and largest design competitions in the world.



reddot award 2018  
winner







# Stand By Me, a journey to customer satisfaction

It's time to relax. With your customer's new Daikin installation and Stand By Me service programme, you can rest assured they are benefiting from the best comfort, energy efficiency, usability and service available on the market. Stand By Me eliminates your clients' worries and provides them with a free, extended warranty, quick follow-up from Daikin service providers, and additional warranties for specific parts.

## Discover in detail the Daikin Metroline

Have a detailed look at each stop to see how our tools can facilitate your journey with Daikin.



NEW



### Heat Pump Calculator

Provides you with leads that come with more in-depth details

 Web portal  Consumer



### Heating Solutions Navigator

Provide the best fit solution for your customers homes

 Web portal  Professionals



### Daikin e-Care

Access to registration, commissioning, configuration and trouble shooting

 Mobile app  Professionals



### Stand By Me

Manage your installation database and offer comfort and service to your customer

 Web portal  Professionals



### Onecta app

End-user app to control the residential unit

 Mobile app  Consumer

NEW

# Discover the new features

We keep investing in the support towards our installers. With your Daikin account, you have access to Stand By Me and the Heating Solutions Navigator online. Use the same account to access the Daikin e-Care app. The tools offer now new features, check it out!



### Heating Solutions Navigator

Newest function:  
Multi-Family Home  
Daikin Home Controls



### Heat Pump Calculator

Summer Cooling  
Winter Heating



### Stand By Me

Newest functions:  
Trainings for professionals (SBM CP Program)  
Direct Service offering from professionals to end-users via SBM ((Daikin à la Carte)



### Daikin e-Care

Newest function:  
Guided commissioning via online check list  
Support for trouble shooting  
Direct access to installation manuals

## Guided commissioning via online checklist

e-Commissioning is the latest tool released in the e-Care app, aiming to improve the quality and reliability of Daikin installations. It is a step-by-step checklist that assists service partners during the commissioning of the unit.

- > Product-specific and country-specific checklist, to ensure maximum flexibility of use and compliance with local requirement
- > Get instant feedback if there are problems with the checklist (screen will display an error message)
- > Generated PDF report available at all times via the e-Care app or via the SBM professional portal
- > Generated commissioning declaration that is automatically sent to the end user in case of successful commissioning
- > Possibility to save a draft of the checklist at any time
- > Offline use (from Dec '23)
- > Possibility to upload pictures of the installation site (from April '24)
- > Possibility to add end user and professional signatures (from Dec '23)
- > Available for Altherma units

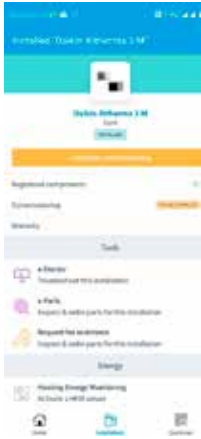

e-Care installation details after Registration

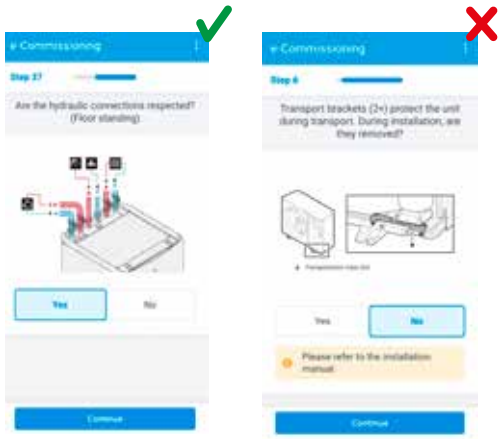

Example of the correct answer

Example of the incorrect answer

Scan the QR code to download Daikine e-Care now



## Get on board on our train to ultimate customer satisfaction

On our underground map, you can discover all the tools we offer to Daikin installers to help them from the first point of contact with a new client, to the maintenance and repair after installation.

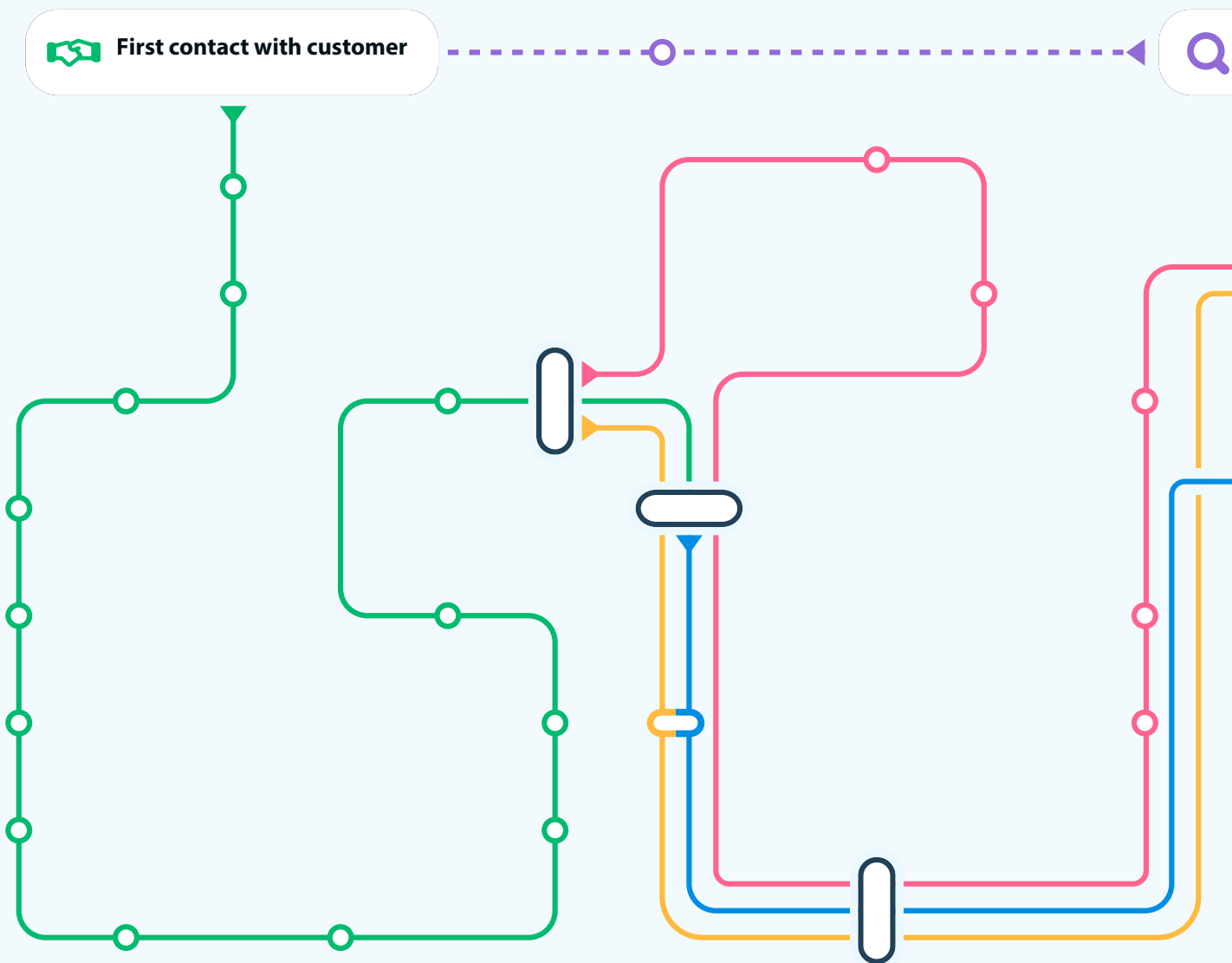

Scan the QR code or go to <http://metro.standbyme.daikin.eu> for the tool

Customers explore solutions

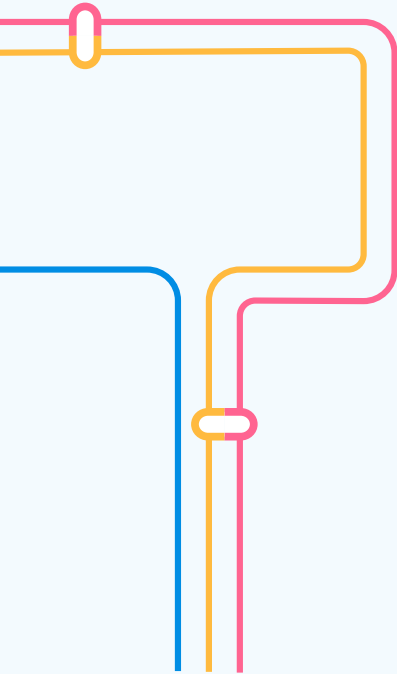

 Ultimate customer satisfaction

**Heating Solutions Navigator**

- Do the radiator test
- Simplified heat load
- Room by Room Heat Load Calculation
- Radiator selection
- Heatpump Convector
- End user quotation
- Piping & Wiring
- Thermal solar calculation tool
- Underfloor heating
- Pipe sizing
- Ventilation
- Literature
- Economic Viability Study
- e-Configuration tool
- Installation registration

**Daikin e-Care**

- e-Configuration tool
- Hydrobalancing tool
- Installation registration
- Commissioning tool
- Maintenance
- Maintenance guide
- e-Doctor
- Installation monitoring
- Spareparts ordering
- Repair

**Stand By Me**

- e-Configuration tool
- Installation registration
- Installation monitoring
- Warranty extension
- Maintenance
- Repair

**Daikin ONECTA App**

- Installation registration
- Warranty extension
- Maintenance
- Repair
- Remote control

**Heat Pump Calculator**

- Heat Pump Calculator



# Combination table and options

			H/O
			3 R MT
			ELVH12S18E6V
			ELVH12S18E9W
			ELVH12S23E6V
			ELVH12S23E9W
Type	Description	Material name	
Outdoor unit		ERRA08EV3/W1	⊙
		ERRA10EV3/W1	⊙
		ERRA12EV3/W1	⊙
Controller	Madoka wired room thermostat	BRC1HHDK/S/W	⊙
	Wireless room thermostats	EKRTRB	⊙
	Wired digital thermostat	EKRRTWA	⊙
	WLAN module	BRP069A71	⊙
	LAN module	BRP069A62	⊙
	WLAN cartridge	BRP069A78	⊙ (1)
	Wired digital thermostat	EKWCTRD1V3	⊙
	Wired analog thermostat	EKWCTRANIV3	⊙
	Wired underfloor heating base station	EKWUFHTAIV3	⊙
	Universal centralized controller	EKCC8-W, DCOM-LT/IO, LT/MB	⊙
Domestic hot water	Stainless steel tank	EKHWS(P)(U)150D3V3	
		EKHWS(P)(U)180D3V3	
		EKHWS(P)(U)200D3V3	
		EKHWS(P)(U)250D3V3	
		EKHWS(P)(U)300D3V3	
	Polypropylene tank	EKHWP300B	
		EKHWP500B	
		EKHWP300PB	
		EKHWP500PB	
	Third party tank kit	EKHY3PART	
EKHY3PART2			
Sensors	External sensor for EKRTRB room thermostat	EKRTETS	⊙
	High voltage smart grid relay kit	EKRELSG	⊙
	Remote indoor temperature sensor	KRCS01-1	⊙ (6)
	Remote outdoor temperature sensor	EKRSCA1	⊙ (6)
	Generic Bizone kit (PCB only)	EKMIKPOA	⊙
	Generic Bizone kit	EKMIKPHA	⊙
Other options	Digital I/O PCB	EKRPIHBA	⊙ (7)
	Demand PCB	EKRPIAHT	⊙
	PC USB cable	EKPCCAB4	⊙
	Conversion kit H/O to reversible for floor standing	EKHVCONV4	⊙
	Conversion kit H/O to reversible for wall mounted	EKHBCONV	
	Booster heater kit	EKBH3SD	
ECH <sub>2</sub> O options	Inline BUH - connection kit	EKECBUCO2AF	
	Inline BUH - 3kW, for *3V (1N~, 230 V, 3 kW)	EKECBUAF3V	
	Inline BUH - 6kW, for *6V (1N~, 230 V, 6 kW)	EKECBUAF6V	
	Inline BUH - 9kW, for *9WN (3N~, 400 V, 9 kW)	EKECBUAF9W	
	Caleffi sludge and magnetite separator SAS1	156021	
	Biv Connector Kit	EKECBIVCO2AF	
	DB connector Kit	EKECDBCO2AF	
	Solar kit HT incl. pump station	EKSRRPS4A	
Daikin Home Controls	Room thermostat	EKRCTRD12BA	⊙
	Room thermostat 2	EKRCTRD13BA	⊙
	Room sensor	EKRSENDI1BA	⊙
	Access point	EKRACPUR1PA	⊙
	Radiator thermostat	EKRRTVTR2BA	⊙
	Floor Heating Controller	EKRUFHT61V3	⊙
	Actuator	EKWCVATR1V3	⊙
	Basic IO Box	EKRSIBDI1V3	⊙
	Multi IO Box	EKRMI BEV1V3	⊙
Daikin Home Hub	EKRHH	⊙	

(1) Included in accessory bag.

(2) Dedicated connection kit: EKEPRHLT3HX.

(3) Dedicated connection kit: ETBH: EKEPRHLT5H / ETBX: EKEPRHLT5X.

(4) EKHY3PART can be used if you have a tank in which you can insert the thermostat.

(5) EKHY3PART2 can be used if you have a tank in which you can't insert a thermostat.

(6) Only one sensor can be connected: indoor or outdoor.

(7) Additional relays to allow bivalent control in combination with external room thermostat are field supply.

(8) Only 1 Backup heater can be connected on one unit: 3 or 6\* or 9 kW (\*No 6T1-model applicable). EKECBUCO2AF is needed to connect the backup heater to the main unit.

(9) Only bivalent models.

(10) Only needed for 300 models. 500 models do not need DB connector kit to install DB solar system.

(11) Models EKHWU150DV3, EKHWU180DV3, EKHWU200DV3, EKHWU250DV3 and EKHWU-300DV3 are not available for the UK.



Floor standing integrated tank		Floor standing integrated ECH <sub>2</sub> O	Wall mounted	
Reversible	Bizone		H/O	Reversible
3 R MT	3 R MT	3 R MT	3 R MT	3 R MT
ELVX12S18E6V	ELVZ12S18E6V	ELSH(B)12P30E		
ELVX12S18E9W	ELVZ12S18E9W	ELSH(B)12P50E		
ELVX12S23E6V	ELVZ12S23E6V	ELSX(B)12P30E	ELBH12E6V	ELBX12E6V
ELVX12S23E9W	ELVZ12S23E9W	ELSX(B)12P50E	ELBH12E9W	ELBX12E9W
●	●	●	●	●
●	●	●	●	●
●	●	●	●	●
●	●	●	●	●
●	●	●	●	●
●	●	●	●	●
●	●	●	●	●
●	●	●	●	●
● (1)	● (1)	● (1)	● (1)	● (1)
●	●	●	●	●
●	●	●	●	●
●	●	●	●	●
			● (11)	● (11)
			● (11)	● (11)
			● (11)	● (11)
			● (11)	● (11)
			● (11)	● (11)
			● (11)	● (11)
			● (2)	● (2)
			● (3)	● (3)
			● (2)	● (2)
			● (3)	● (3)
			● (4)	● (4)
			● (5)	● (5)
●	●	●	●	●
●	●	●	●	●
● (6)	● (6)	● (6)	● (6)	● (6)
● (6)	● (6)	● (6)	● (6)	● (6)
●		●	●	●
●		●	●	●
● (7)	● (7)	●	● (7)	● (7)
●	●	●	●	●
●	●	●	●	●
	●		●	
		●		
		● (8)		
		● (8)		
		● (8)		
		●		
		● (9)		
		● (10)		
		●		
●	●	●	●	●
●	●	●	●	●
●	●	●	●	●
●	●	●	●	●
●	●	●	●	●
●	●	●	●	●
●	●	●	●	●
●	●	●	●	●
●	●	●	●	●
●	●	●	●	●



**Daikin Europe N.V.** Naamloze Vennootschap Zandvoordestraat 300 · 8400 Oostende · Belgium · [www.daikin.eu](http://www.daikin.eu) · BE 0412 120 336 · RPR Oostende (Publisher)

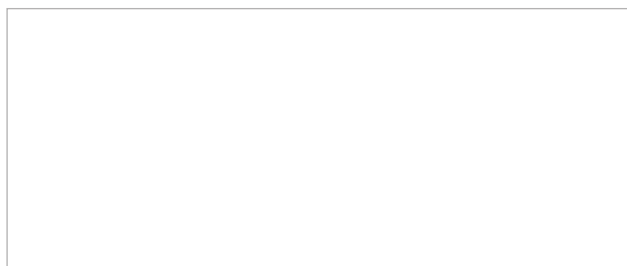

ECPEN23-720A

01/24



The present publication is drawn up by way of information only and does not constitute an offer binding upon Daikin Europe N.V. Daikin Europe N.V. has compiled the content of this publication to the best of its knowledge. No express or implied warranty is given for the completeness, accuracy, reliability or fitness for particular purpose of its content and the products and services presented therein. Specifications are subject to change without prior notice. Daikin Europe N.V. explicitly rejects any liability for any direct or indirect damage, in the broadest sense, arising from or related to the use and/or interpretation of this publication. All content is copyrighted by Daikin Europe N.V.

Printed on non-chlorinated paper.