

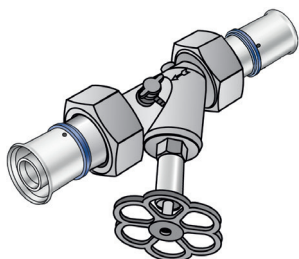

## KMU452 KELOX-ULTRAX Schrägsitzventil



### Produktbeschreibung:

Schrägsitzventil, mit ULTRAX Press-Verschraubungen KMU455, Oberteil „todraumfrei“, flach dichtend inkl. Dichtung und Entleerung, „unverpresst undicht“



kiwa



### Produkteigenschaften:

<b>Presskontur</b>	U
--------------------	---

### Erweiterte Produkteigenschaften:

Art.-Nr.	Bezeichnung	Gewicht	VPE1	Mengeneinheit
71233BB0	16-DN15	0,49 KGM	1	SA1
71233DD0	20-DN15	0,52 KGM	1	SA1
71233EE0	25-DN20	0,82 KGM	1	SA1
71233FF0	32-DN25	1,1 KGM	1	SA1

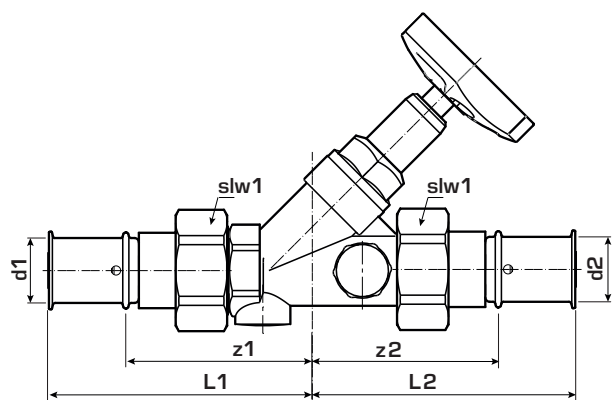

Art.-Nr.	Bezeichnung	d1/d2 mm	L1 mm	z1 mm	L2 mm	z2 mm	slw1
71233BB0	16-DN15	16	81	52	81	58	49
71233DD0	20-DN15	20	82	56	82	56	51
71233EE0	25-DN20	25	103	70	103	70	57
71233FF0	32-DN25	32	115	82	115	82	67

