

## 5. Dimensional Drawings

### 5.2 Outdoor Unit

PC09SQ (S3UM09JA2FA), PC12SQ (S3UM12JA2FA), S09EQ (S3UW09JA3AA),  
S12EQ (S3UW12JA3AA), SC09EQ (S3UM09JA3BA), SC12EQ (S3UM12JA3BA)

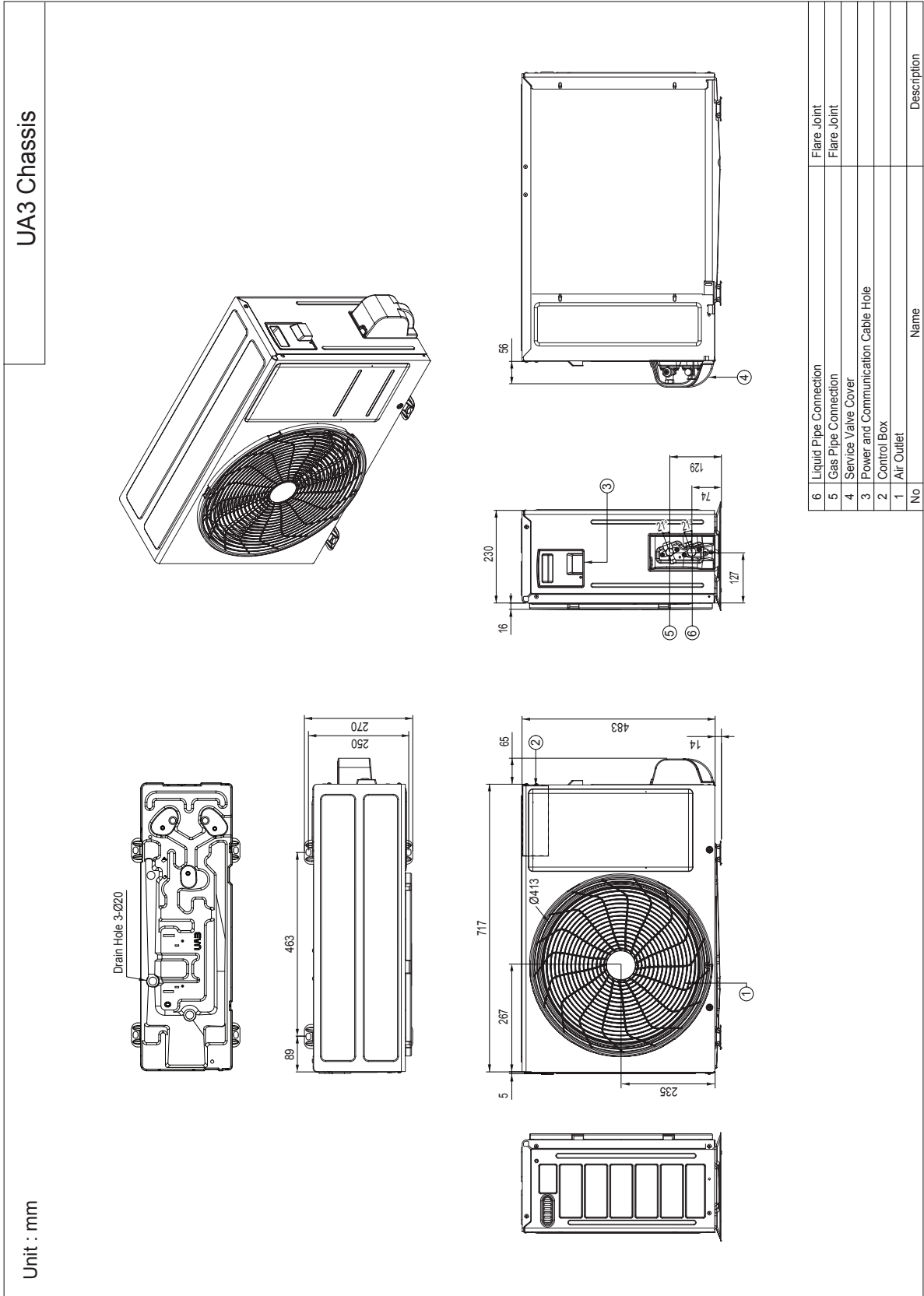

Unit : mm